

herkules™

G415

OWNERS MANUAL



INSTRUCTIONS

This manual contains important information concerning the installation and operation of the gun washer listed above. **Read manual thoroughly and keep for future reference.**

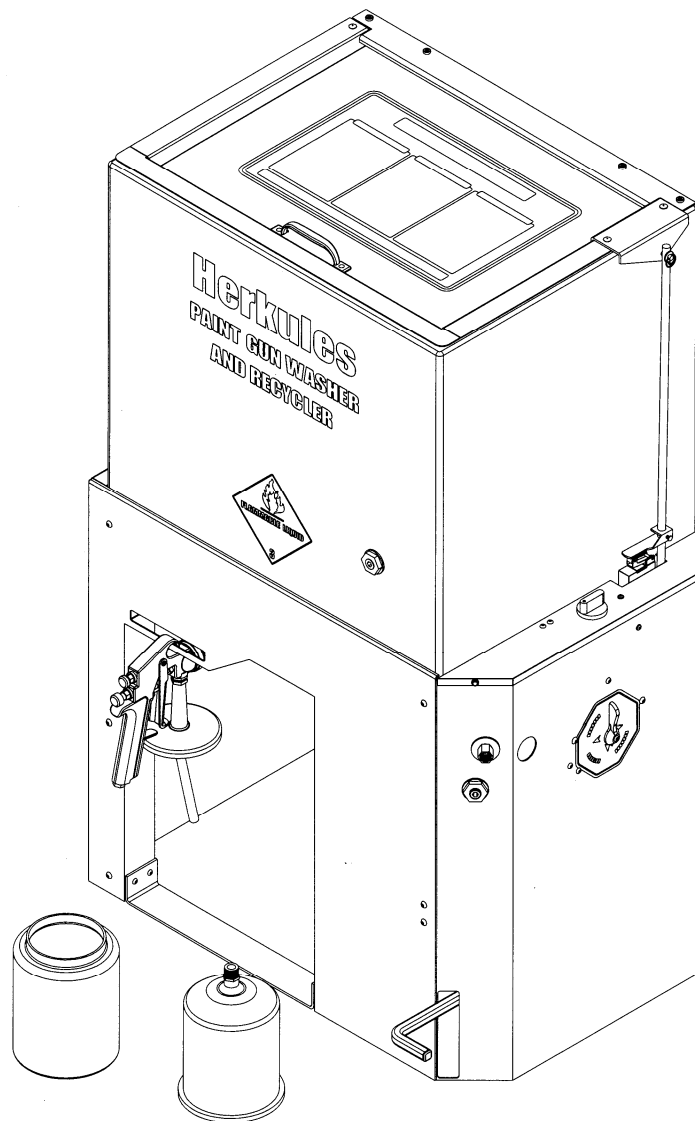

Herkules Equipment Corporation ■ 2760 Ridgeway Court ■ Walled Lake, MI 48390-1662 USA
248-960-7100 ■ 1-800-444-4351 ■ Fax 248-960-7109
Patents USA 4793369, 4960142, 5174317, 5193561, 5485860 Canada 1299468 Made in the USA
website: www.herkules.us e-mail: info@herkules.us

Table of Contents

Warnings	3-4
Model Information	5
Installation	6
Operation	7-9
Preventive Maintenance	10
Troubleshooting	11
Notes	12-13
Parts layout for G415	14-16

Warning Symbol



This symbol alerts you to the possibility of serious injury or death if you do not follow the instructions.

Serial Number _____

Distributor _____

Caution Symbol



This symbol alerts you to the possibility of damage to or destruction of equipment if you do not follow the instructions.

Purchase Date _____

Model Number _____

WARNING



INSTRUCTIONS

EQUIPMENT MISUSE HAZARD

Equipment misuse can cause the equipment to rupture, malfunction, or start unexpectedly and result in serious injury.

- This equipment is for professional use only.
- Read all instruction manuals, tags, and labels before operating the equipment.
- Use the equipment only for its intended use.
- Do not alter or modify this equipment.
- Do not exceed the maximum working pressure of the lowest rated system component.
- Do not operate the gun washer at a pressure above the maximum working pressure rating of the gun(s) being cleaned.
- Route the hoses away from traffic areas, sharp edges, moving parts, and hot surfaces.
- Do not use the hoses to pull the equipment.
- Do not move pressurized equipment.
- Use fluids or solvents that are compatible with the equipment wetted parts. Read the fluid and solvent manufactures warnings.
- Comply with all applicable local, state and national fire, electrical and other safety regulation.



PRESSURIZED EQUIPMENT HAZARD

Spray from hose leaks, ruptured components, or from operating the gun washer with an open lid can splash fluid in the eyes or on the skin and cause serious injury.

- A safety device has been installed to shut off the pump when the gun washer lid is opened. Do not tamper with or alter this device.
- Open the gun washer lid slowly.
- Do not prop the gun washer lid open with an object or by any other means.
- Do not stop or deflect fluid leaks with your hand, body, glove, or rag.
- Tighten all fluid connections before operating the equipment.
- Replace worn, damaged, or loose parts immediately.

WARNING



FIRE AND EXPLOSION HAZARD

Improper grounding, poor air ventilation, open flames, or sparks can cause a hazardous condition and result in fire or explosion and serious injury.



- Ground the equipment. See Installation for grounding procedure.
- Provide fresh air ventilation to avoid the build up of flammable fumes from the solvent.
- Extinguish all open flames or pilot lights in gun washer area.
- Electrically disconnect all equipment in the gun washer area.
- Keep the gun washer area free of debris, including solvent, rags, and gasoline.
- Do not turn on any light switch in the gun washer area while operating or if fumes are present.
- Do not smoke in the gun washer area.
- Do not operate a gasoline engine in the gun washer area.
- Follow the gun manufactures solvent and other cleaning recommendations.
- Use solvent with the highest possible flash point.
- If there is any static sparking while using the equipment, **stop operation immediately**. Identify and correct the problem.
- Drain the solvent into a proper storage container when gun washer(s) is not in use.



TOXIC FLUID HAZARD

Hazardous fluids or toxic fumes can cause serious injury or death if splashed in eyes or on the skin, swallowed, or inhaled.

- Know the specific hazards of the fluid you are using. Read the fluid manufactures warnings.
- Store hazardous fluid in an approved container. Dispose of hazardous fluid according to all local, state and national guidelines.
- Wear the appropriate protective clothing, gloves, eyewear and respirator.
- Pipe and dispose of the exhaust air safely. If diaphragm fails, the fluid may be exhausted along with the air.

Model Information

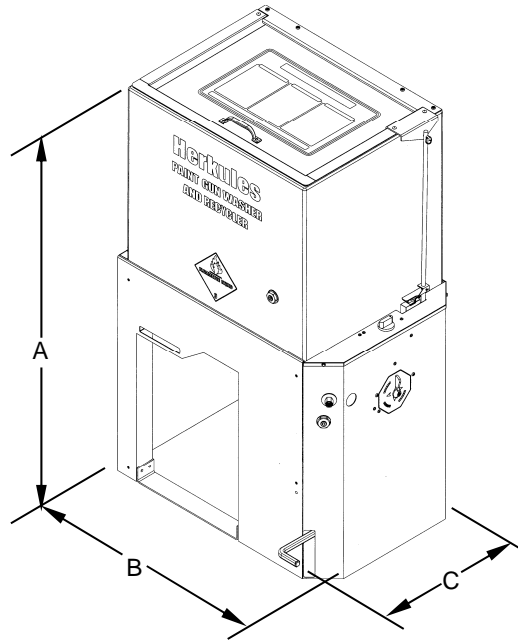

Model	Description	Weight lb. (kg.)	Dimension in. (mm.)		
			A	B	*C
G415	Equipped with two diaphragm pumps, one for washing and one for rinsing. Adapted for cleaning pressure pot systems paint hoses, and cans up to five gallons plus a hand held brush for manual cleaning of parts. Includes a factory installed Fume Extractor.	87 (39.5)	42 (1067)	**25.5 (648)	*18 (457)

Notes:

* Foot Pedal protrudes an additional 4.5" (114 mm.) past the front of the Gun Washer.

** Must allow room for 5-gallon can of solvent for the clean rinse option on the left side or rear of the Gun Washer.

Installation

Installing the Gun Washer

Place gun washer on a level surface in a properly ventilated paint mixing room.

Connection the Foot Operated Lid Opener

1. Align the hole in the Lid Rod with the hole in the Lid Bracket and insert the Clevis Pin through the holes (see fig. 1).
2. Place the 1/4" Flat Washer over the Clevis Pin
3. Attach the Circle Cotter Pin to the Clevis Pin (see Fig. 1).

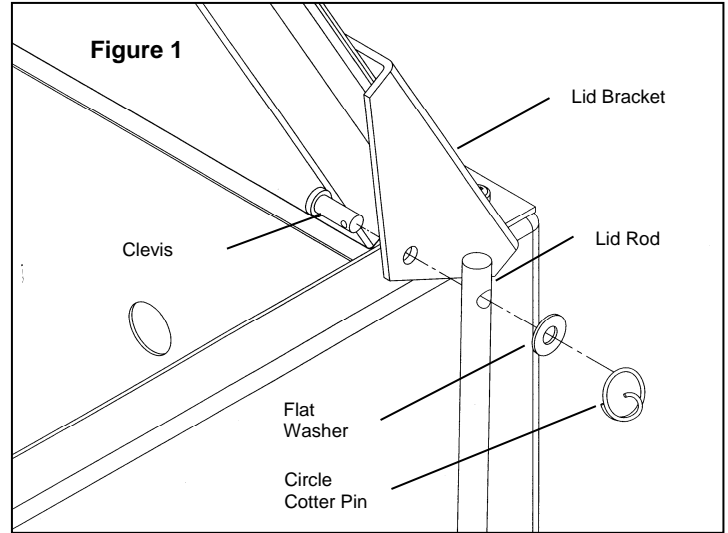

Grounding the Gun Washer

1. Connect the ground wire on the gun washer's pump to a true earth ground.
2. Ground all equipment used or located in the gun washer area.

Connecting the Air Line

1. Install a 1/4 in. npt male coupler, that is compatible with the quick disconnect of your air supply line, into the air inlet fitting (see Fig. 2).
2. Connect air line with 90-120 psi to the coupler.

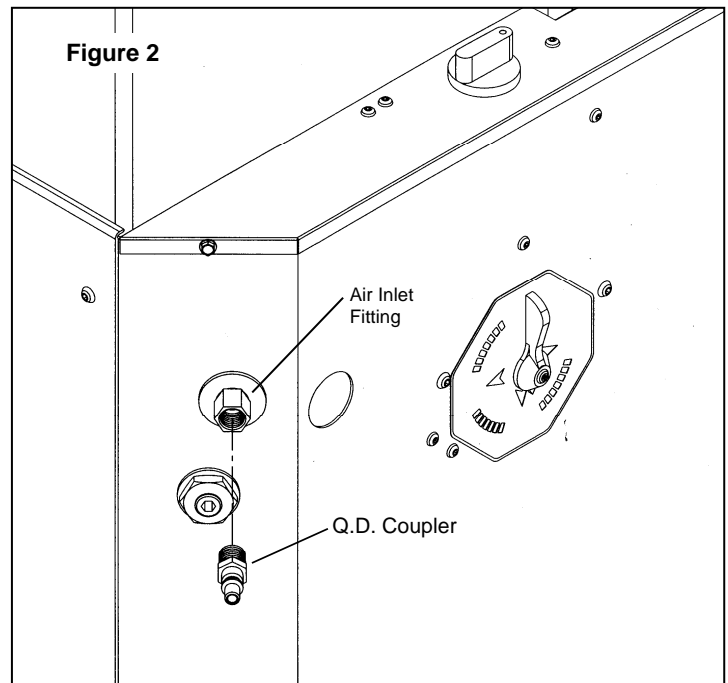

CAUTION

Do not change the setting of the filter/regulator. this could damage the filter/regulator or pump.

Operation

Filling the Gun Washer with Fluid

1. Close ball valve located on the bottom of the tank.
2. Pour five gallons (18.9 liters) of high quality, slow evaporating solvent into the tank.

Preparing the Equipment to be Washed

1. Remove paint cup or paint line and the air line from the paint gun.
2. Drain excess paint from cup and gun.
3. Remove all gauges and regulators.

CAUTION

All pressure gauges must be removed before placing the equipment in the gun washer to avoid damaging the gauges.

4. Lock the gun trigger in the open position by placing the trigger lock around the gun handle and trigger (see Fig. 3).

Placing Equipment in the Gun Washer

To clean guns not mentioned here, use the long or short stem supports as needed (see Fig. 3). For questions or adapter kits contact your paint gun washer distributor.

Siphon Feed Guns

Place the gun siphon tube on the short stem support.

Gravity Feed Guns (HVLV)

Place the long stem support over the short stem support. Place paint inlet of gun on long stem support. Place the air cap assembly over the air inlet of the gun to keep solvent out.

Pressure Feed Guns

Place the long stem support over the short stem support. Place paint inlet of gun on long stem support.

Pots and Cups

Place pots and/or cups on divider platform over front spray nozzles.

Figure 3

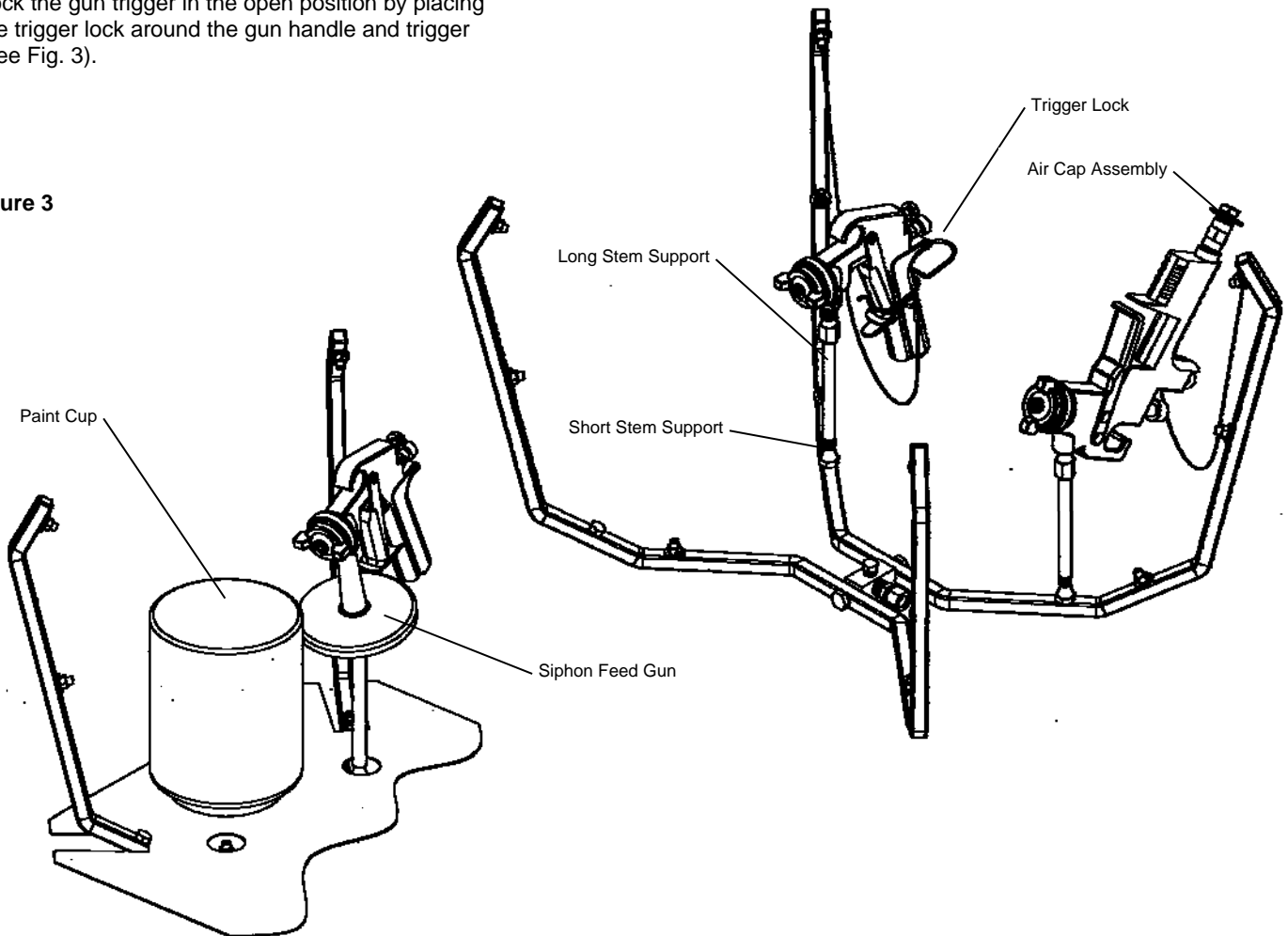

Operation

Additional Hose and Can Washing Features

Internal Washing of Paint Lines

Remove the brass plugs from the hose wash bulkheads (see Fig. 4). Install a female fluid quick coupler with 1/4 in. npt male threads (suitable for lacquer thinner) into the hose wash bulkheads. Connect the paint line to the couplers. Set the pointer on the shield to hose clean and operate the gun washer. Reinstall the brass plugs when resuming normal gun cleaning operations.

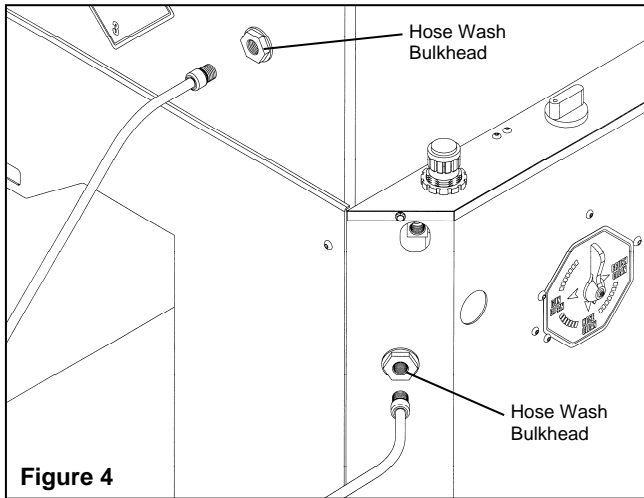

Internal Washing of Paint Lines with Guns Attached

Remove the brass plug from the hose wash bulkhead on the front of the shield. Install a female fluid quick coupler with 1/4 in. npt male threads (suitable for lacquer thinner). Connect paint line with gun attached, to the coupler. Set the pointer on the shield to the hose clean position and operate the gun washer. To "bleed" the paint (into a container) hold the trigger of the gun open until thinner begins to flow. Reinstall the brass plug when resuming normal gun cleaning operations.

Internal and External Washing of Paint Lines with Guns Attached

Remove the hex plug from the manifold block and install a female fluid quick coupler with 1/4 in. npt male threads (suitable for lacquer thinner) into the center of the manifold (see Fig. 5). Connect the paint line with gun attached, to the coupler. Place the paint line with gun attached inside the gun washer. Lock the gun trigger in the open position with the wire trigger lock. Set the pointer on the shield to the gun clean position. Operate the gun washer. Reinstall the hex plug when resuming normal gun cleaning operations.

Washing Pressure Pot and Lid

Remove the hex plug from the manifold block and insert the spray nozzle assembly, hanging on the back of the manifold, into the manifold block (see Fig. 5). Place pot over spray nozzle. Place the pickup tube of lid over one of the short stem supports (remove gauges). Operate gun washer. Reinstall the hex plug when resuming normal gun cleaning operations.

Washing Five Gallon Cans

Remove the hex plug from the manifold block and insert the spray nozzle assembly, hanging on the back of the manifold, into the manifold block (see Fig. 5). Place five-gallon can over spray nozzle. Operate gun washer. Reinstall the hex plug when resuming normal gun cleaning operations.

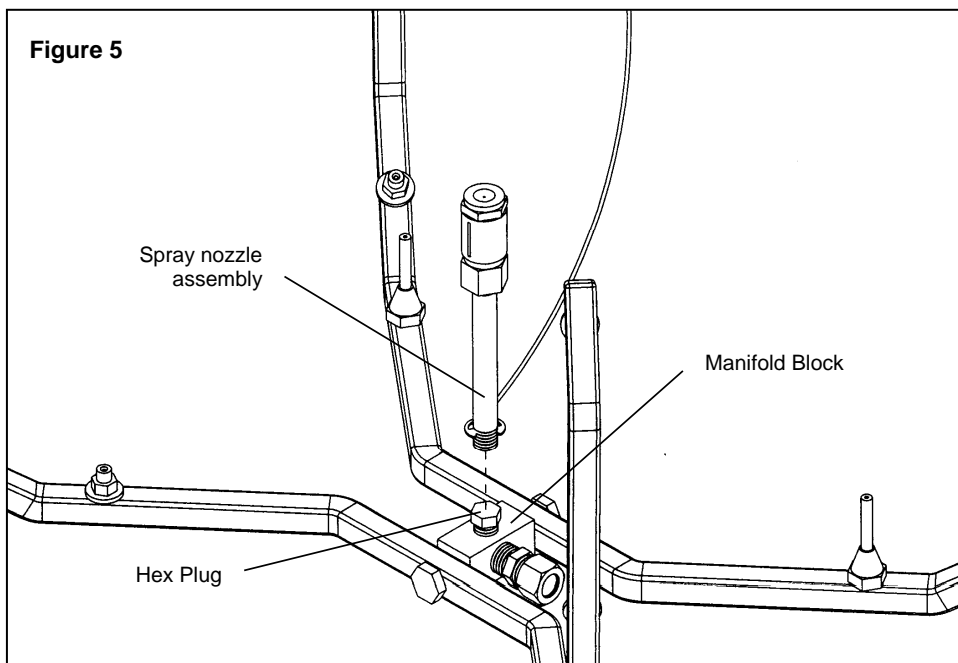

Operation

Rinsing of Paint Equipment

Place a five-gallon can of clean solvent next to gun washer. Remove the cap from the can and replace it with the plug provided in the parts bag. Insert the siphon tube through the plug, and position the can in the desired location (see Fig. 6). After the washing cycle is finished, press and hold the rinse button for approximately 3-6 seconds.

Operating Fume Extractor

Attach a 1-1/4" exhaust hose (not included) to the fume extractor on the back of the gun washer (see fig. 6). Run the other end of the hose to the exhaust of the shop paint booth. **DO NOT OPERATE THE GUN WASHER WITHOUT CONNECTING THE EXHAUST HOSE.** The fume extractor will activate whenever the lid is opened.

Figure 6

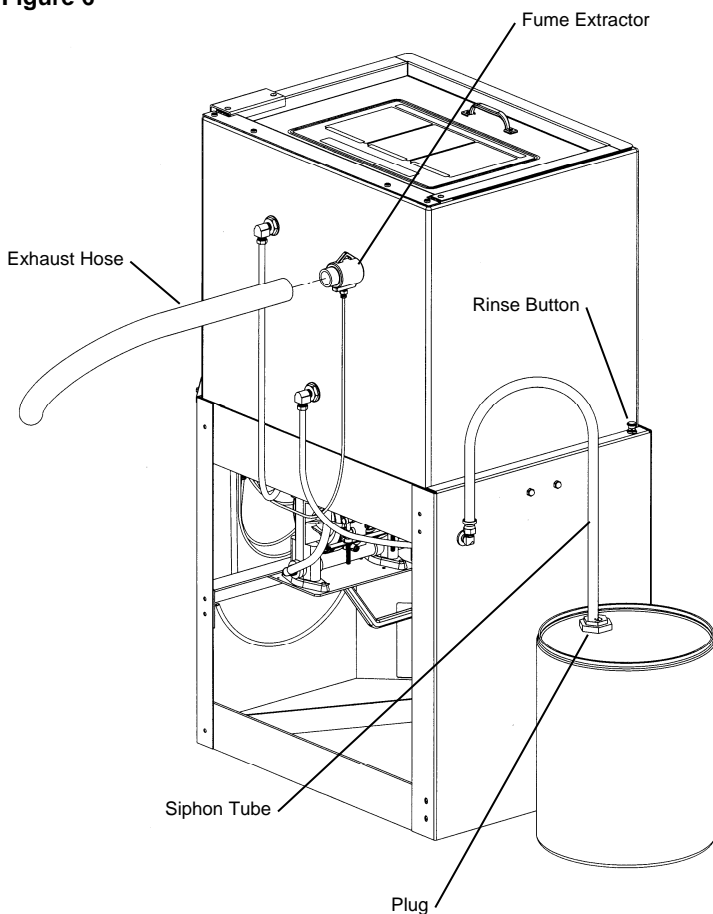

Manual Cleaning of Paint Equipment

1. Set the pointer on the shield to the brush clean position. With the pointer in the brush clean position, the brush will be activated whenever the lid is opened.
2. To increase the flow through the brush, turn the knob of the flow control valve counterclockwise. To decrease the flow through the brush, turn the knob of the flow control valve clockwise.

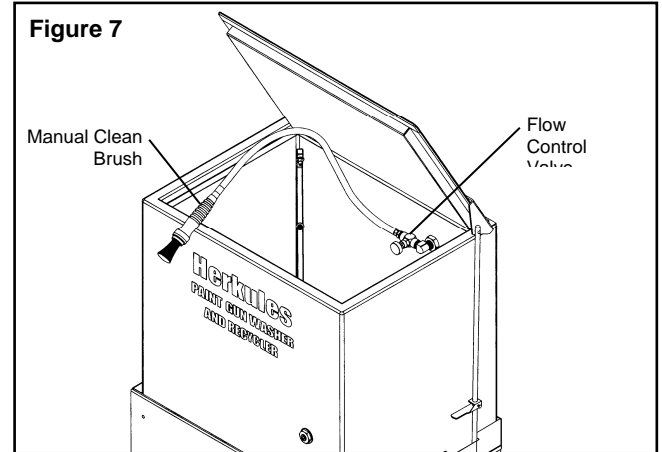

Operating the Gun Washer

1. Make sure all wire trigger locks and other accessories are inside the gun washer tank.
2. If washing only one set of equipment, place empty cans over the unused nozzles and/or stem supports to prevent solvent spray from hitting the underside of the gun washer lid.
3. Close the gun washer lid.
4. Set the pointer to Gun Clean.
5. Turn the timer knob clockwise 90 degrees to the ON position to start the gun washer. The gun washer will run for 90 seconds. Turning the timer knob less than 90 degrees will reduce the timing cycle. Paint equipment will clean in 60 to 90 seconds.

6. If the lid is opened prior to the end of the timing cycle, the safety air cutoff switch will stop the gun washer. The gun washer will start again when the lid is closed if time remains on the timer.

Note: Open and close the lid slowly to minimize solvent vapor escape.

7. Remove the equipment from the gun washer and wipe off any remaining solvent. The gun hanger on the front of the stand can be used to dry the guns.

Preventive Maintenance

1. Drain excess paint from cup or pot before placing in gun washer.
2. Drain paint sludge from gun washer tank weekly. Do this after a weekend so that it has settled. Open ball valve and drain until clear solvent flows. Add solvent to 1" above intake filter.
4. Remove the filter bowl and check the filter inside the regulator for excess buildup approx. every 6 months
5. Change solvent completely when objects being cleaned become tacky to the touch.
6. Clean inside of tub and intake filter assembly #12491 before filling with solvent.

CAUTION

Do not change the setting of the filter/regulator. This could damage the filter/regulator or pump.

Figure 8

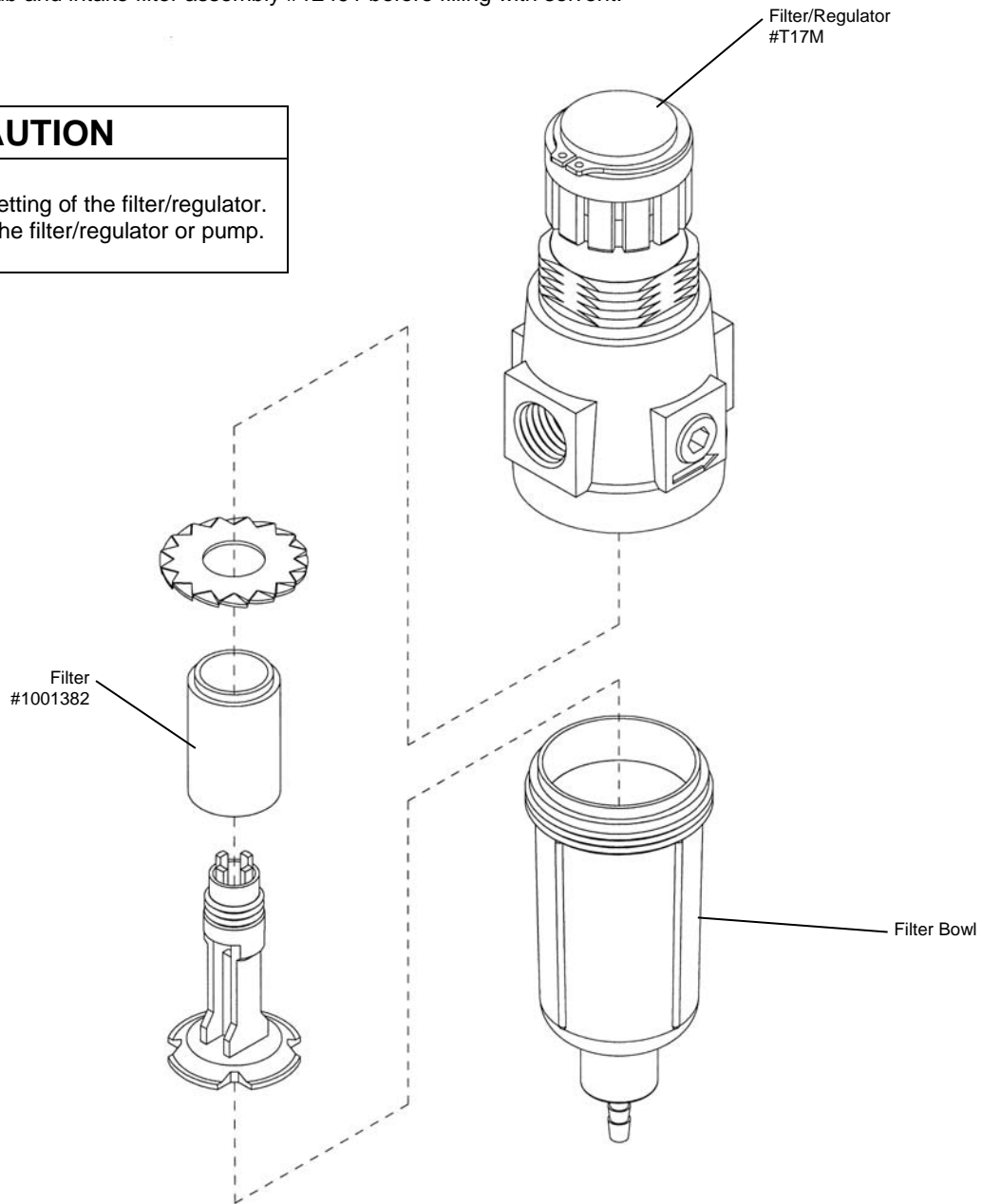

Troubleshooting

Problem	Possible Solution
Gun washer will not turn on.	<ol style="list-style-type: none"> 1. Make sure the air line is properly connected with 90-120 psi. 2. Make sure lid is fully closed. Make sure the limit valve on the pump bracket is closed in the downward position. 3. Check all air connections to ensure that there are no leaks. 4. Make sure timer cam is engaging the limit valve (#M1C) on the shield assembly. 5. Make sure timer is on and functioning correctly.
Gun washer turns on but pumps slowly or not at all.	<ol style="list-style-type: none"> 1. Make sure intake filter (#12491) is not clogged (Clean or replace). 2. Make sure the air line is properly connected with 90-120 psi. 3. Check all air connections to ensure that there are no leaks. 4. Drain filter/regulator of water. See number 3 of PREVENTIVE MAINTENANCE. 5. Make sure there are 5 gallons of clean solvent in the gun washer. The solvent should be an inch above the intake filter (#12491). 6. Make sure lid is fully closed. Make sure the limit valve on the pump bracket is closed in the downward position. 7. Make sure manifold nozzles and stem supports are not clogged.
Gun washer will not shut off.	<ol style="list-style-type: none"> 1. Make sure timer cam (#M230-001A) is moving. If its not, slightly loosen the nuts holding the limit valve (#M1C) on the shield. Reposition valve and tighten nuts.
Rinse cycle will not work.	<ol style="list-style-type: none"> 1. Check the level of the rinse solvent. 2. Check all fluid connections to ensure that there are no leaks.
Manual Brush will not work	<ol style="list-style-type: none"> 1. Clean or replace the brush filter (see fig. 7). 2. Check Orifice plate for obstructions (see fig. 7).

Parts Layout for G415

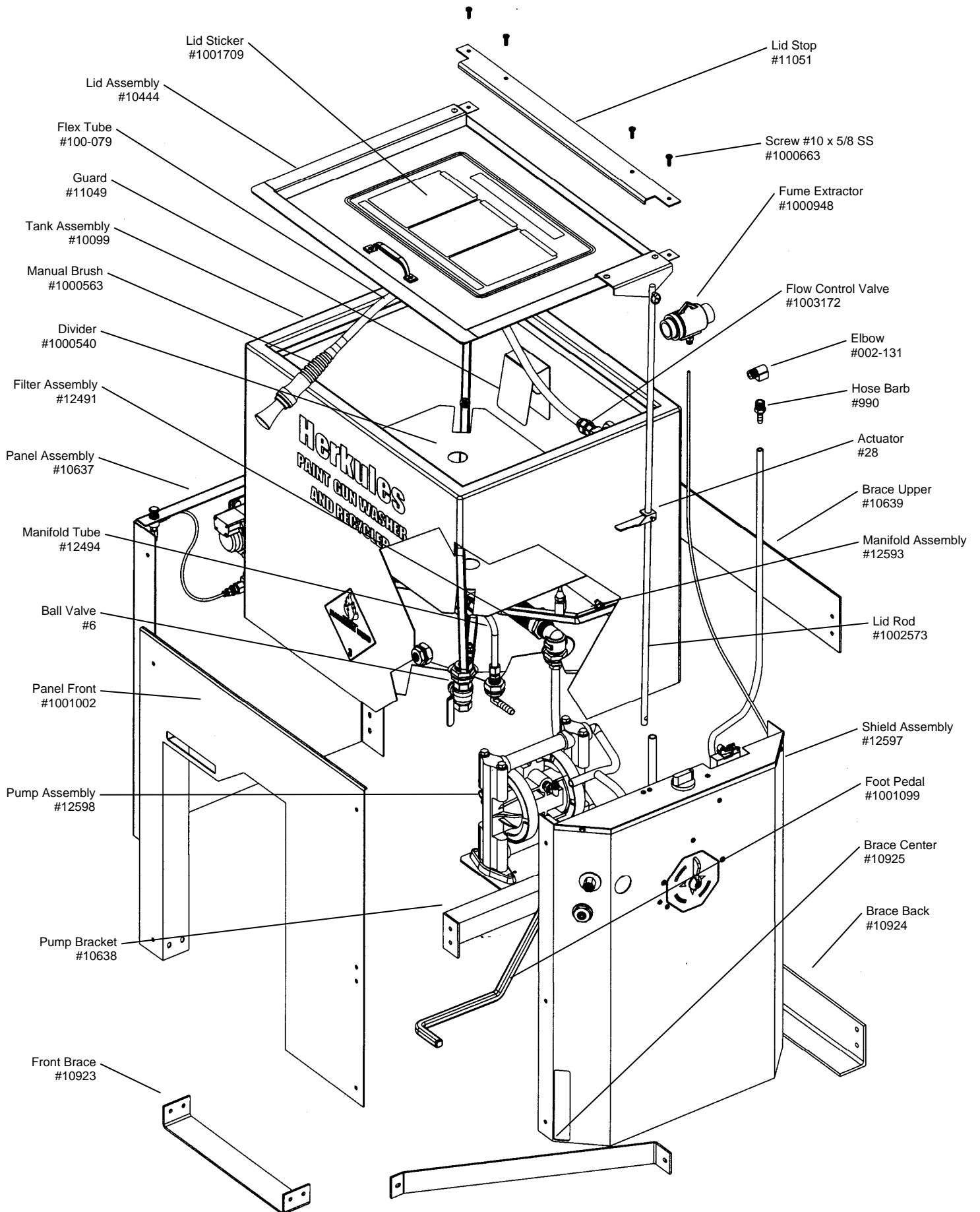

Shield Assembly #1000000

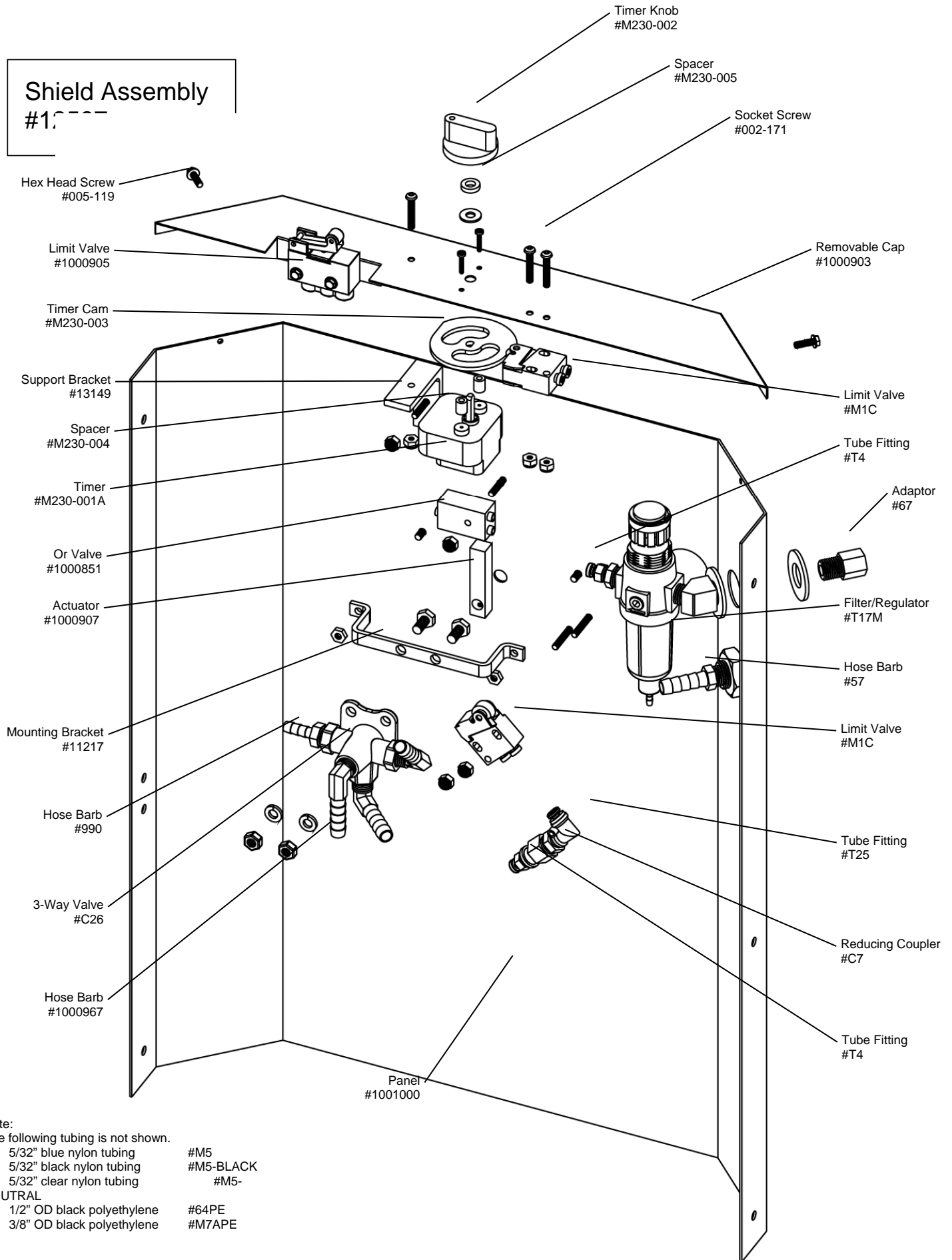

Note:
The following tubing is not shown.

5/32" blue nylon tubing	#M5
5/32" black nylon tubing	#M5-BLACK
5/32" clear nylon tubing	#M5-

NEUTRAL

1/2" OD black polyethylene	#64PE
3/8" OD black polyethylene	#M7APE

**Manifold Assembly
#12596**

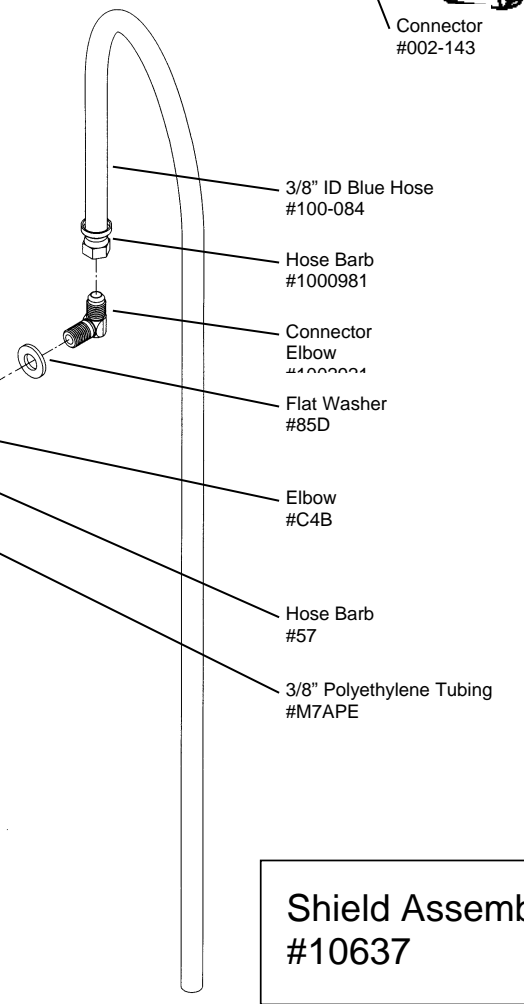
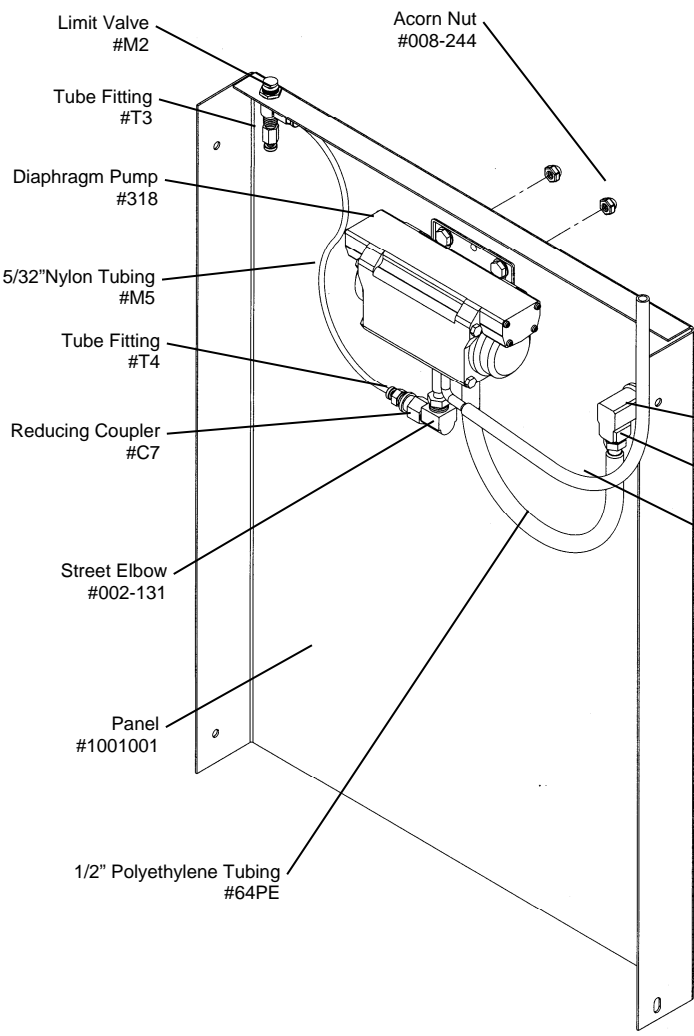
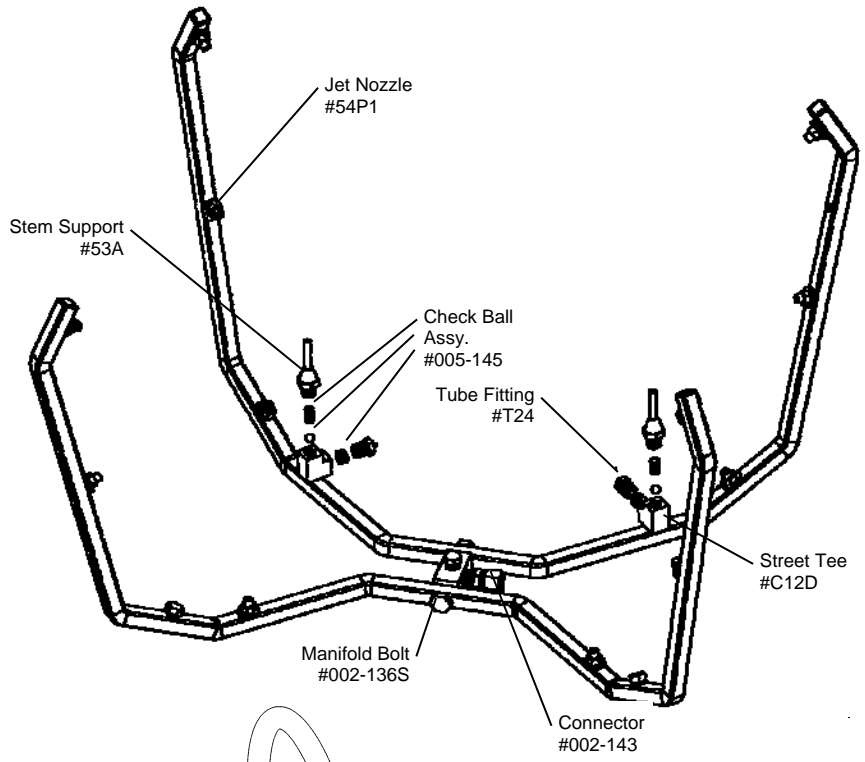

**Shield Assembly
#10637**