

# herkules

Equipment Corporation

Part# 1000163  
3-7-01 TN

Manufacturing Systems and Equipment for the Automotive and Industrial Markets



## OWNERS MANUAL



**INSTRUCTIONS**

This manual contains important information concerning the installation and operation of the equipment listed below. **Read manual thoroughly and keep for future reference.**

## PARTSMOBILE

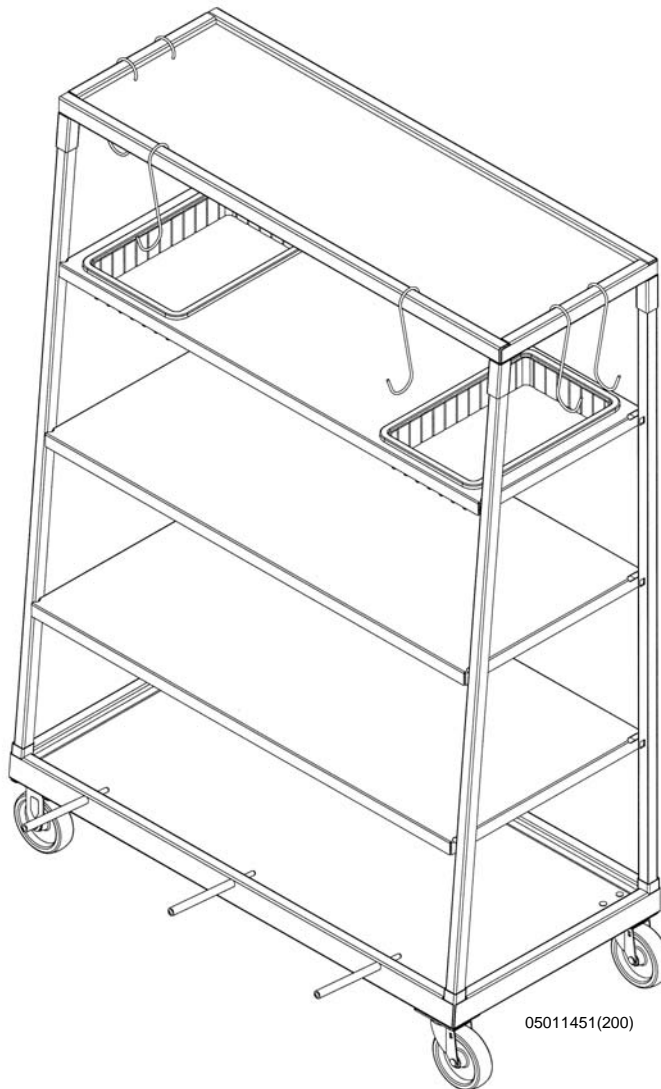

05011451(200)

Herkules Equipment Corporation ■ 2760 Ridgeway Court ■ Walled Lake, MI 48390-1662 USA  
248-960-7100 ■ 1-800-444-4351 ■ Fax 248-960-7109

## Model Information:

Model	Capacity (kg.)	Shelf Capacity (kg.)	Shelves (per unit)	Weight (kg.)	Dim. A (mm.)	Dim. B (mm.)	Dim. C (mm.)
PM-1	600 lbs. (272)	200 lbs (91)	4	100 lbs (45)	47 in. (1194)	21.75 in. (552)	66.5 in. (1689)
PM-2	600 lbs. (272)	200 lbs (91)	2	70 lbs (32)	47 in. (1194)	21.75 in. (552)	66.5 in. (1689)

Model Shown: PM-1

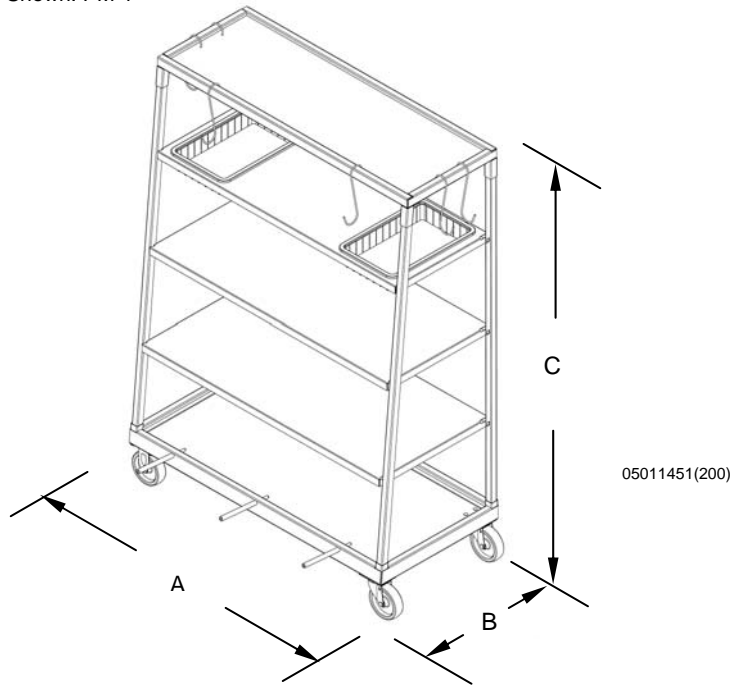

### PM-1 Contents

2	Upright Tubes	#1001420
2	Upright Tubes	#1001421
1	Bottom Shelf	#1001415
1	Large Shelf	#1001416
1	Middle Shelf	#1001417
1	Small Shelf	#1001418
1	Top Shelf	#1001419
2	Ridged Casters	#001-700
2	Swivel Casters	#001-701
2	Parts Trays	#001-401
8	S-Hooks	#001-600A
3	Support Pegs	#10185
12	Carriage Bolts	#1001413
12	Star Lock Nuts	#1001414

### PM-2 Contents

2	Upright Tubes	#1001420
2	Upright Tubes	#1001421
1	Bottom Shelf	#1001415
1	Large Shelf	#1001416
1	Top Shelf	#1001419
2	Ridged Casters	#001-700
2	Swivel Casters	#001-701
8	S-Hooks	#001-600A
12	Carriage Bolts	#1001413
12	Star Lock Nuts	#1001414

## Assembly:

- Attach the 2 Ridged Casters to one end of the Bottom Shelf Assembly using 3 Carriage Bolts and 3 Star Lock Nuts per caster (See Figure 1).
- Attach the 2 Swivel Casters to the other end.
- Set the Bottom Shelf Assembly on the Casters and insert the 4 Upright Tubes into the 4 Mounting Pegs (See Figure 2)  
Note: The tabs on the Upright tubes must face upward and inward.
- Set the Large Shelf on the lowest set of tabs.
- \*5. Set the Middle Shelf on the next set of tabs (See Figure 2).
- \*6. Set the Small Shelf on the last set of tabs and place the 2 Parts Trays into the openings (See Figure 2).
- Place the Top Shelf Assembly over the 4 Upright Tubes and inset the 4 Upright Tubes into the Mounting Pegs of the Top Shelf Assembly (See Figure 2).
- Use S-Hooks and \*Support Pegs as needed.

\* PM-1 Only.

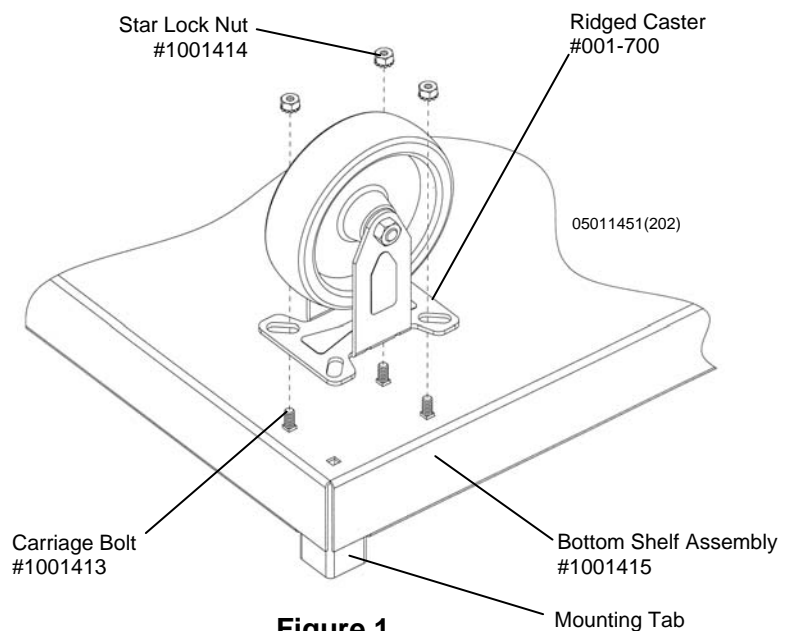

Figure 1

# Partsmobile Parts Layout

Figure 2

