

G210

OWNERS MANUAL



This manual contains important information concerning the installation and operation of the gun washers listed above. Read manual thoroughly and keep for future reference

INSTRUCTIONS

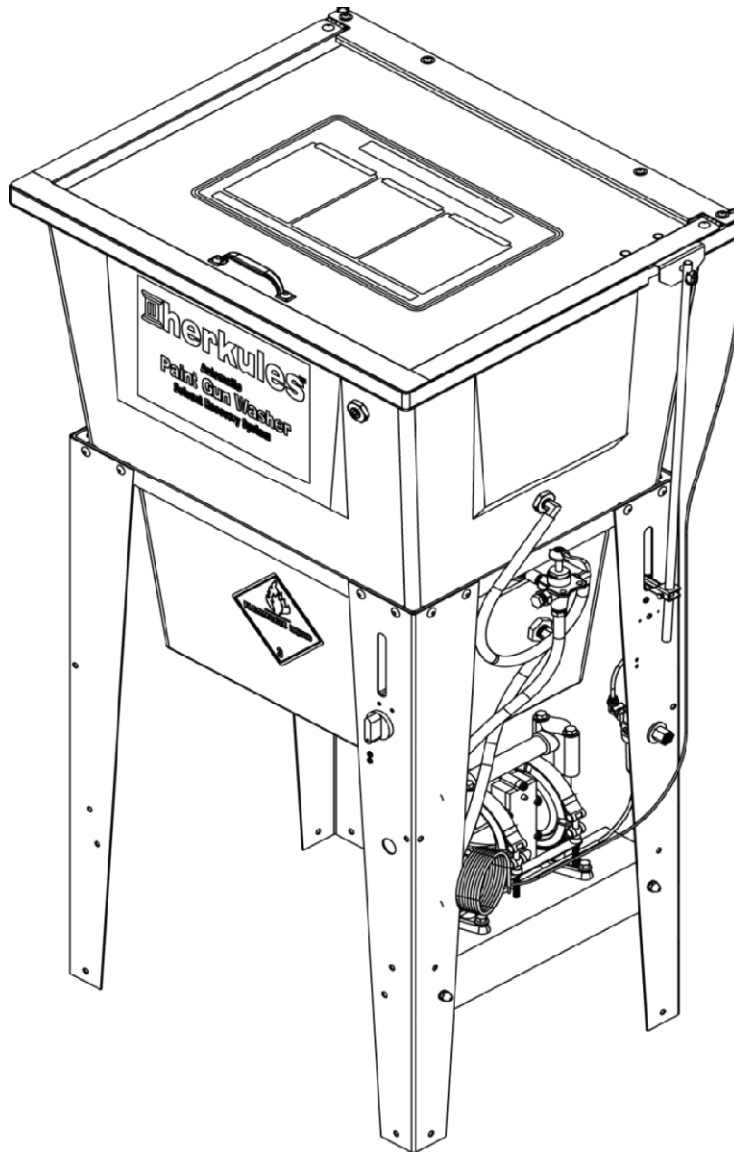

Herkules Equipment Corporation
248-960-7100

2760 Ridgeway Court
800-444-4351

Walled Lake, MI 48390-1662 USA
Fax 248 960-7109

Patents USA 7070167 4793369, 4960142, 5174317, 5193561, 5485860 Canada 1299468 & Patents Pending

website: www.herkules.us

Made in the USA

e-mail: info@herkules.us

Table of Contents

Warnings	3-4
Assembly Instructions	5-6
Model Information	7
Installation	7
Operation	8-10
Preventive Maintenance	10
Troubleshooting	11
Drawings with part lists:	12-18
Notes	19

Warning Symbol



This symbol alerts you to the possibility of serious injury or death if you do not follow the instructions.

Caution Symbol



This symbol alerts you to the possibility of damage to or destruction of equipment if you do not follow the instructions.

Serial Number _____

Model Number _____

Purchase Date _____

Distributor _____

PATENT NUMBERS

This product has patent protection under one or more of the following patent numbers:

7070167, 5485860, 5193561, 5174317
4960142, 4793369, 1299468
and Patents Pending

website: www.herkules.us

1002742



WARNING



EQUIPMENT MISUSE HAZARD

Equipment misuse can cause the equipment to rupture, malfunction, or start unexpectedly and result in serious injury.

- This equipment is for professional use only.
- Read all instruction manuals, tags, and labels before operating the equipment.
- Use the equipment only for its intended use.
- Do not alter or modify this equipment.
- Do not exceed the maximum working pressure of the lowest rated system component.
- Do not operate the gun washer at a pressure above the maximum working pressure rating of the gun(s) being cleaned.
- Route the hoses away from traffic areas, sharp edges, moving parts, and hot surfaces.
- Do not use the hoses to pull the equipment.
- Do not move pressurized equipment.
- Use fluids or solvents that are compatible with the equipment wetted parts. Read the fluid and solvent manufacturer's warnings.
- Comply with all applicable local, state and national fire, electrical and other safety regulation.



PRESSURIZED EQUIPMENT HAZARD

Spray from hose leaks, ruptured components, or from operating the gun washer with an open lid can splash fluid in the eyes or on the skin and cause serious injury.

- A safety device has been installed to shut off the pump when the gun washer lid is opened. Do not tamper with or alter this device.
- Open the gun washer lid slowly.
- Do not prop the gun washer lid open with an object or by any other means.
- Do not stop or deflect fluid leaks with your hand, body, glove, or rag.
- Tighten all fluid connections before operating the equipment.
- Replace worn, damaged, or loose parts immediately.



WARNING



FIRE AND EXPLOSION HAZARD



Improper grounding, poor air ventilation, open flames, or sparks can cause a hazardous condition and result in fire or explosion and serious injury.

- Ground the equipment. See Installation for grounding procedure.
- Provide fresh air ventilation to avoid the build up of flammable fumes from the cleaning solution.
- Extinguish all open flames or pilot lights in the gun washer area.
- Disconnect all electrical equipment in the gun washer area.
- Keep the gun washer area free of debris, including cleaning solutions, rags, and gasoline.
- Do not turn on any light switch in the gun washer area while operating or if fumes are present.
- Do not smoke in the gun washer area.
- Do not operate a gasoline engine in the gun washer area.
- Follow the gun manufacturer's solvent and other cleaning recommendations.
- Use solvent with the highest possible flash point.
- If there is any static sparking while using the equipment, **stop operation immediately**. Identify and correct the problem.
- Drain the cleaning solution into a proper storage container when gun washer(s) is not in use.



TOXIC FLUID HAZARD

Hazardous fluids or toxic fumes can cause serious injury or death if splashed in eyes or on the skin, swallowed, or inhaled.

- Know the specific hazards of the fluid you are using. Read the fluid manufacturer's warnings.
- Store hazardous fluid in an approved container. Dispose of hazardous fluid according to all local, state and national guidelines.
- Wear the appropriate protective clothing, gloves, eyewear and respirator.
- Pipe and dispose of the exhaust air safely. If diaphragm fails, the fluid may be exhausted along with the air.

Assembly

Stand and tub connections

STEP 1

Position the pump mount bracket between the timer leg and the filter/regulator leg of the stand assembly. Attach the pump mount bracket to the stand using (2) 1/4-20 x 1/2 hex bolts, (2) #10 flat washers, (2) 1/4" lock washers and (2) 1/4" acorn nuts per leg (see fig.1).

STEP 2

Attach the pump to the stand using the (2) 1/4-20 x 1 hex bolts, (2) 1/4" flat washers, (2) 1/4" lock washers and (2) 1/4" hex nuts per leg (see fig.2).

STEP 3

Attach the ball valve to the reducing nipple on the bottom of the tub and set tub in the stand (see fig.3). Use a sealant on the ball valve/bulkhead to avoid leaking.

STEP 4

Attach the white plastic muffler to the exhaust port of the pump (see fig.3).

STEP 5

Slide (1) #10 flat washer then (1) 1/8" nylon spacer then the timer knob over the shaft protruding from the timer leg assembly (see fig.3)

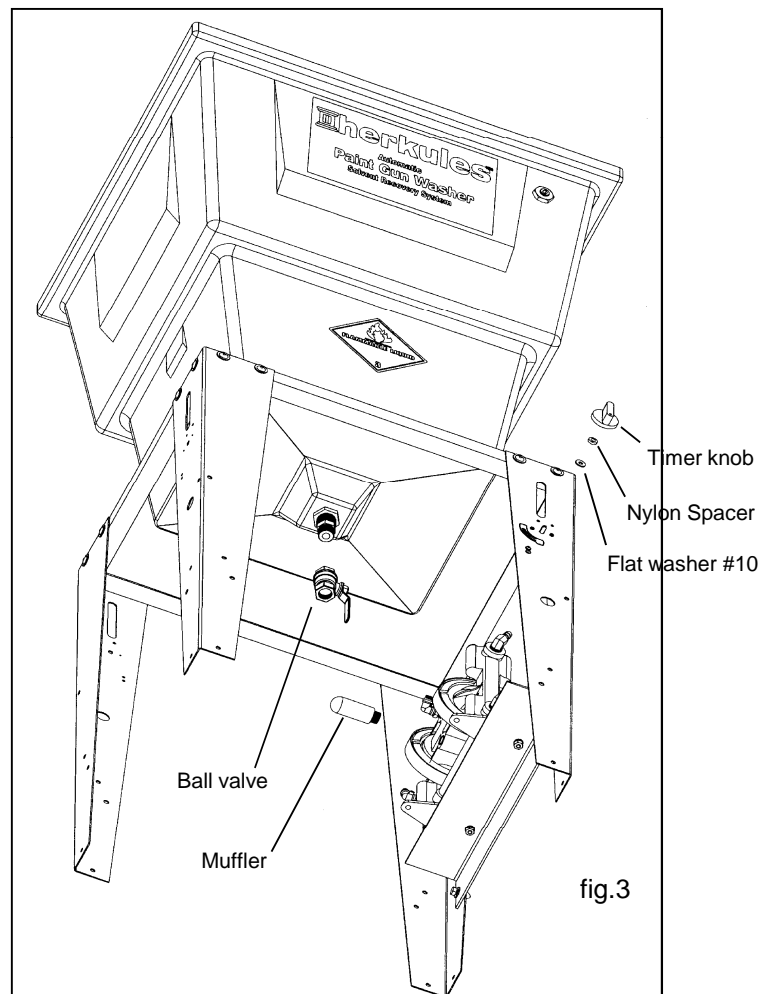
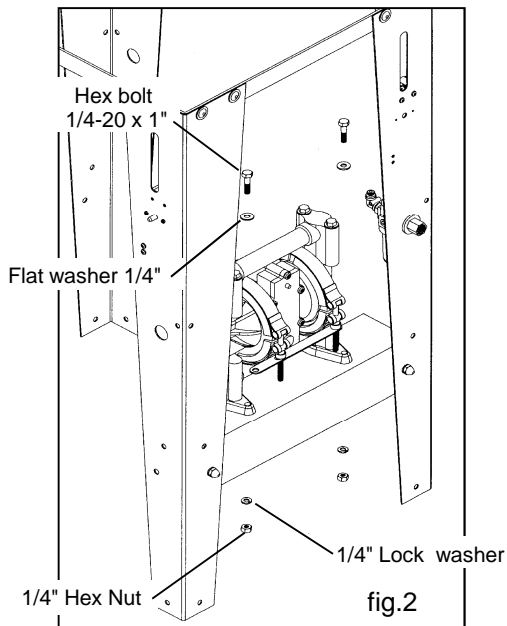
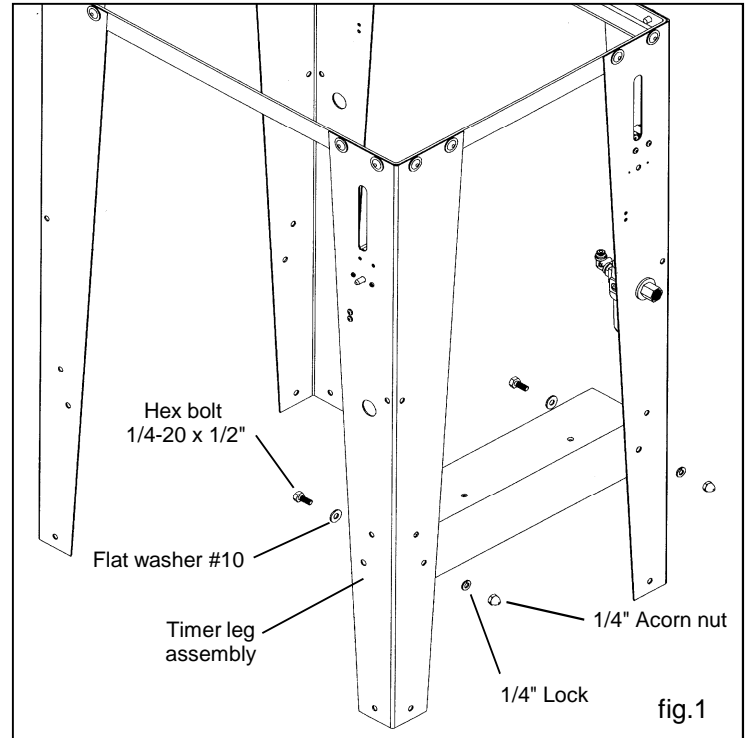

Assembly

Connecting fluid and air hoses

STEP 6

Insert the nipple and bushing end of the 3-way valve assembly into the upper bulkhead in the tub. Use sealant to avoid leaking and orient as shown (see fig.4).

STEP 7

Connect the 13" long fluid outlet tube between the fluid outlet port of the pump and the straight barb on the valve. DO NOT HEAT HOSE (see fig.4).

STEP 8

Connect the 16" long fluid inlet tube between the fluid inlet port of the pump and the lower bulkhead on the tub. DO NOT HEAT HOSE (see fig.4).

STEP 9

Connect the 20" long fluid tube between the elbow barb on the valve and the elbow barb on the tub above the valve. DO NOT HEAT HOSE (see fig.4).

STEP 10

Connect the black 5/32" air hose between the regulator and the air in port of the limit valve located on the rear leg of the gun washer (see fig.4).

Note: Air in port of limit valve is the port opposite the roller. For all air hose, press tubing in through collar until seated. Pull firmly on hose to test for a tight connection.

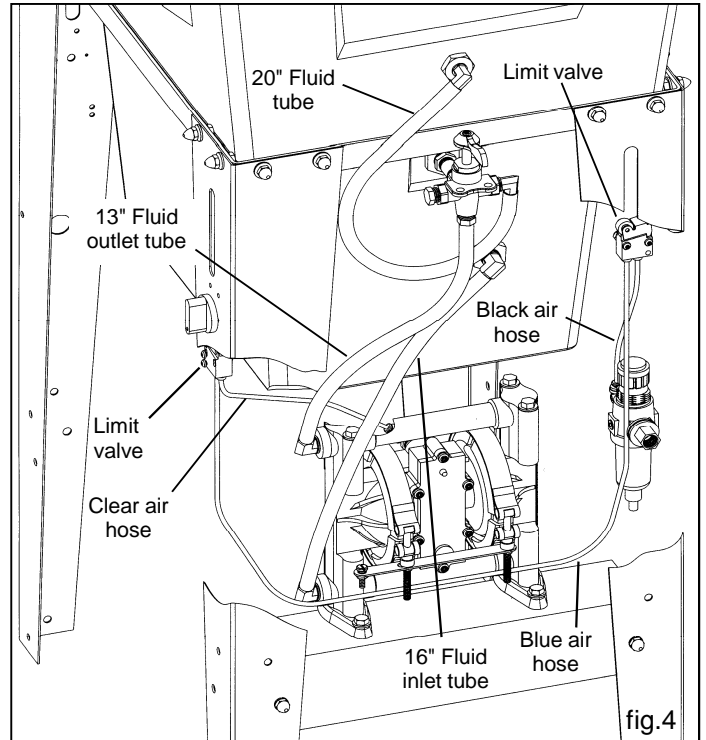

STEP 11

Connect the blue 5/32" air hose between the air in port of limit valve located on the front leg and the air out port of the limit valve located on the rear leg of the gun washer (see fig.4).

STEP 12

Connect the clear 5/32" air hose between the pump and the air out port of the limit valve located on the front leg of the gun washer (see fig.4).

Connecting lid rod and actuator linkage

STEP 13

Slide the actuator over the lid rod opposite the drilled end and hand tighten approx. 4" from the end of the rod. Insert the actuator into the large slot in the right rear leg (see fig 6).

STEP 14

Attach the lid rod to the lid bracket using the 1/4" clevis pin and circular cotter pin supplied (see fig. 5).

STEP 15

To adjust the actuator, close the lid and loosen the set screw on the actuator. Slide the actuator down until it completely closes the limit valve and retighten the set screw (see fig. 6).

Grounding the lid

STEP 16

Using an 1/8" allen wrench, remove the back right lid screw. Connect the ground wire (with the aluminum terminal attached) from the pump to the lid screw and reconnect it to the tub (see fig. 5).

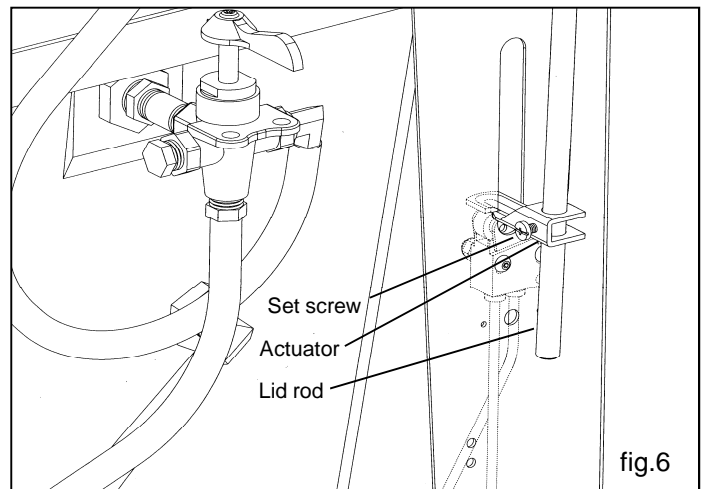
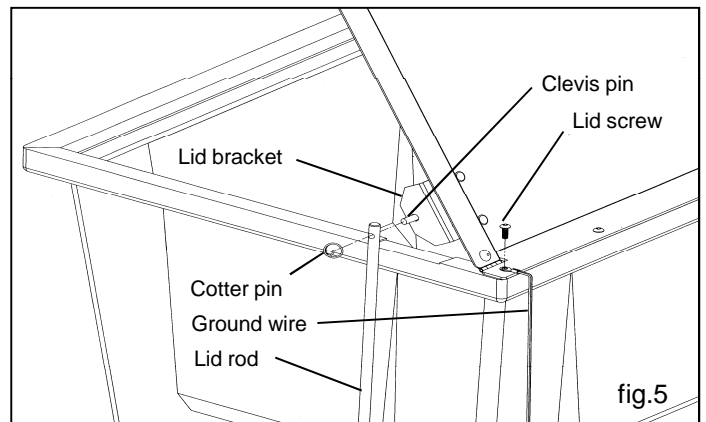

Model Information

Parts bag contents

001-702	Hex bolt 1/4-20 x 1/2	2 ea.
002-161	Flat washer #10	2 ea.
008-244	Acorn nut 1/4-20	2 ea.
001-705	Flat washer 1/4	2 ea.
6	Ball valve	1 ea.
83	Hex bolt 1/4-20 x 1	2 ea.
84	Hex nut 1/4-20	2 ea.
85	Lock Washer 1/4	4 ea.
1000652	Clevis pin 1/4 dia.	1 ea.
1000252	Cotter pin	1 ea.
11957	Actuator	1 ea.
12729	Valve assembly	1 ea.
C9A	Nipple 1/8 NPT X 4-1/2	2 ea.
53B	Stem support female	2 ea.
M230-002	Timer Knob	1 ea.
M230-005	Spacer 1/8" Nylon	1 ea.
M5	Tube 5/32 blue plastic	30 in.
M5-BLACK	Tube 5/32 black plastic	9 in.
M5-NEUTRAL	Tube 5/32 clear plastic	13 in.

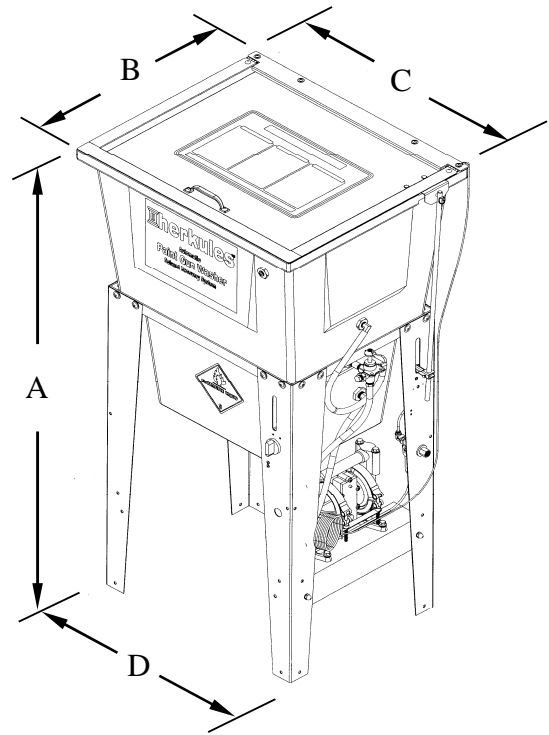

NOTE: Dimensions listed are overall measurements.

Model	Description	Weight lbs/(kg)	Dimensions in./(mm)			
			A	B	C	D
G210	Two gun, two cup paint gun washer equipped with diaphragm pump, filter-regulator and timer. Adapted for pressure feed systems, paint hoses, and cans up to 5 gallons. Cleans both solvent and water based paints.	68 (31)	46 (1168)	20.625 (524)	25.5 (648)	21.25 (540)

Installation

Installing the Gun Washer

- 1) Place gun washer on a level surface in a properly ventilated paint mixing room or paint booth.

Grounding the Gun Washer

- 1) Connect the ground wire on the gun washer's pump to a true earth ground.
- 2) Ground all equipment used or located in the gun washer area.

Connecting the Air Line

- 1) Install a 1/4 in. npt male coupler, that is compatible with the quick disconnect of your air supply line, into the air supply port of the filter/regulator located on the right rear leg (see fig. 7).
- 2) Connect air line with at least 75 psi to the coupler. Filter/regulator is preset. Do not adjust.

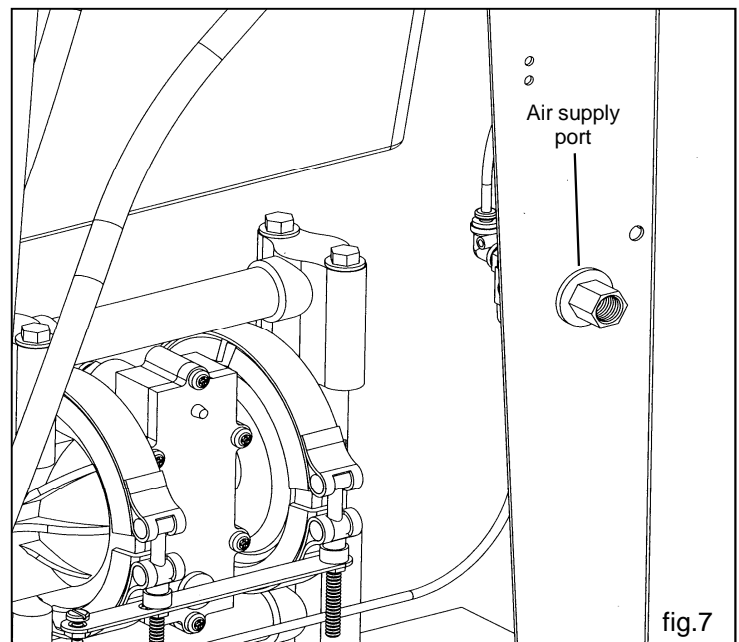

fig.7

Operation

Filling the Gun Washer with Fluid

- 1) Close ball valve located on the bottom of the tank.
- 2) Pour five gallons (18.9 liters) of high quality cleaning solution into the tub. Unit is capable of cleaning both solvent and water based paints.

Preparing the Equipment to be washed

- 1) Remove paint cup or paint line and the air line from the paint gun.
- 2) Drain excess paint from cup and gun.
- 3) Remove all gauges and regulators.
- 4) Lock the gun trigger in the open position by placing the trigger lock around the gun handle and trigger (see fig. 8).

CAUTION

All pressure gauges must be removed before placing the equipment in the gun washer to avoid damaging the gauges.

Placing Equipment in the Gun Washer

To clean guns not mentioned here, use the long or short stem supports as needed (see Fig. 8). For questions or adapter kits contact your paint gun washer distributor.

Siphon Feed Guns

Place the gun siphon tube on the short stem support.

Gravity Feed Guns (HVLV)

Place long stem support over one of the short stem supports. Place paint inlet of gun on long stem support. Place the air cap assembly over the air inlet of the gun to keep cleaning solution out.

Pressure Feed Guns

Place long stem support over one of the shorter stem supports. Place paint inlet of gun on long stem support.

Pots and Cups

Place pots and/or cups on divider platform over front spray nozzles.

fig. 8

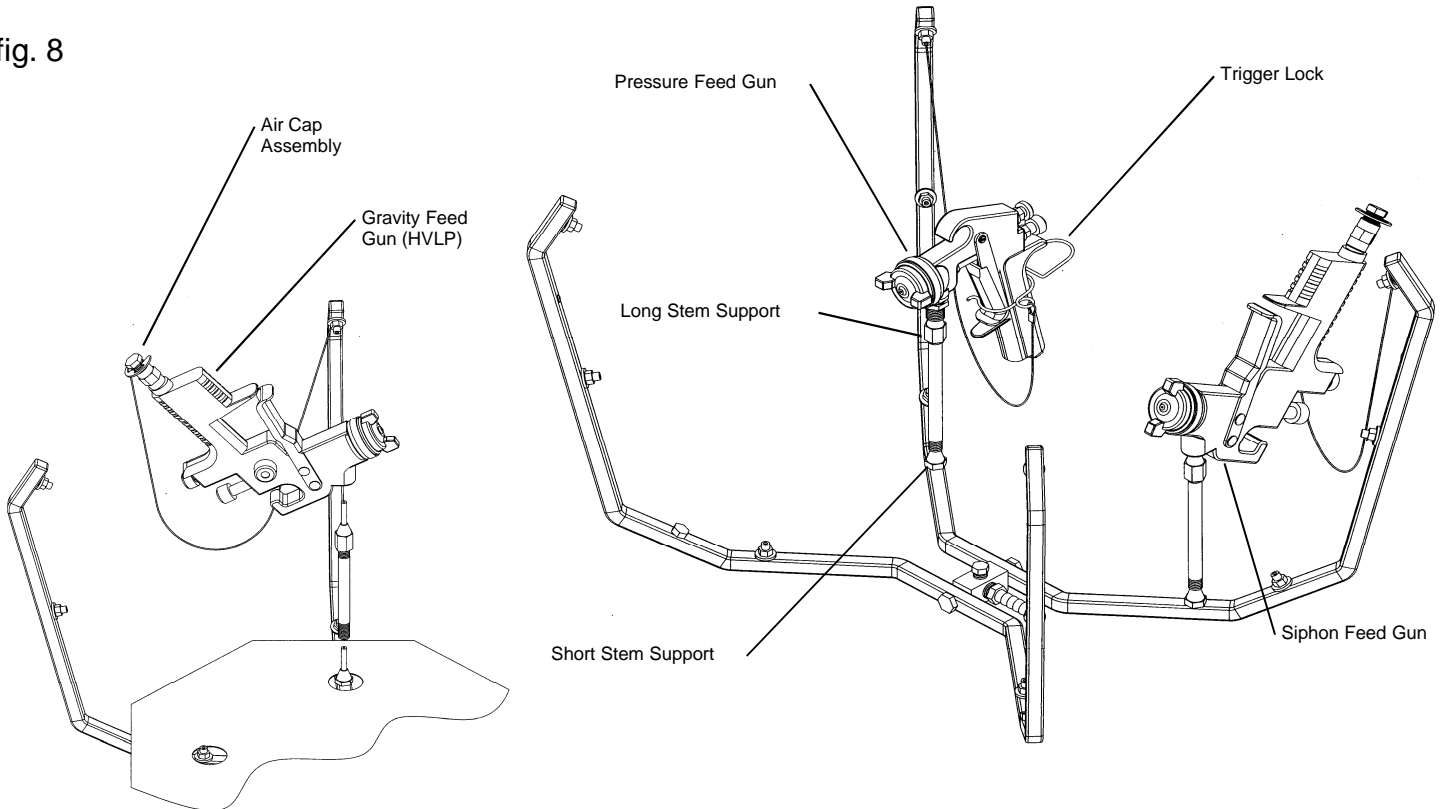

Operation

Operating the Gun Washer

- 1) Make sure all wire trigger locks and other accessories are inside the gun washer tub.
- 2) If washing only one set of equipment, place empty cans over the unused nozzles and/or stem supports to prevent spray from hitting the underside of the gun washer lid.
- 3) Close the gun washer lid.
- 4) Turn the timer knob clockwise 90 degrees to start the gun washer. The gun washer will run for 90 seconds. Turning the timer knob less than 90 degrees will reduce the timing cycle. Paint equipment will clean in 60 to 90 seconds.

- 5) If the lid is opened prior to the end of the timing cycle, the safety air cutoff switch will stop the gun washer. The gun washer will start again when the lid is closed if time remains on the timer.

Note: Open the lid slowly to minimize vapor escape.

- 6) Remove the equipment from the gun washer and wipe off any remaining cleaning solution.

Internal Washing of Paint Lines

- 1) Remove the brass plugs from the front of the 3-way valve and the internal wash bulkhead (see fig.9).
- 2) Install a female fluid quick coupler with 1/4" NPT male threads into one, or both, locations the plugs were removed from. Coupler must be compatible with the solvent you are using.
- 3) Connect the paint line to the 3-way valve and the internal wash bulkhead.
- 4) Face the pointer of the 3-way valve towards the front of the unit and operate the gun washer.

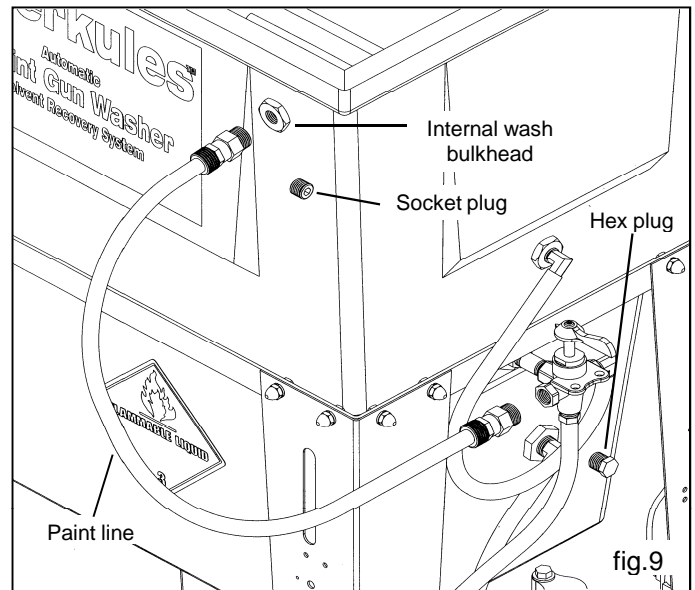

Internal and External Washing of Paint Lines

- 1) If necessary, install a female fluid quick coupler with 1/4" NPT male threads into the internal/external wash bulkhead located inside the tub, on the valve side of the tub (see fig.10).
- 2) Connect the paint line to the internal/external wash bulkhead.
- 3) Face the pointer of the 3-way valve towards the back of the unit and operate the gun washer (internal cleaning portion).
- 4) Face the pointer of the 3-way valve towards the tank and operate the gun washer (external cleaning portion).

Note: When finished cleaning hoses be sure to securely replace all plugs which were removed.

Return the pointer of the 3-way valve to its position facing the tub; failure to do so will cause the gun washer to operate incorrectly.

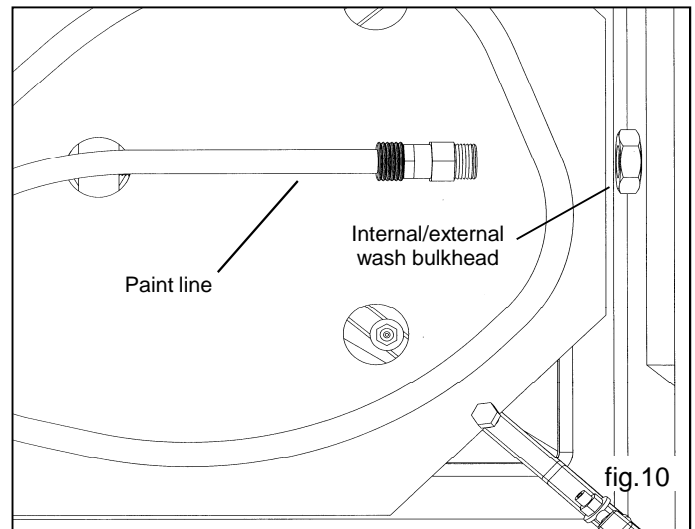

Valve Positions

- Manifold Cleaning
- Internal Paint Line Cleaning
- Internal/External Paint Line Cleaning

Pointer Direction

Towards the tank

Towards the front of the tank

Towards the rear of the tank and towards the tank

Operation

Washing Pressure Pot and Lid

- 1) Remove the 1/8" NPT hex plug from the manifold block (see fig.11).
- 2) Insert the spray nozzle assembly into the manifold block (see fig.11).
- 3) Place the pot over the spray nozzle assembly and place the pickup tube of the lid over one of the short stem supports.
- 4) Operate gun washer.

Washing Five Gallon Cans

- 1) Remove the 1/8" NPT hex plug from the manifold block (see fig.11).
- 2) Insert the spray nozzle assembly into the manifold block. (see fig.11).
- 3) Place five gallon can over the spray nozzle assembly.
- 4) Operate gun washer.

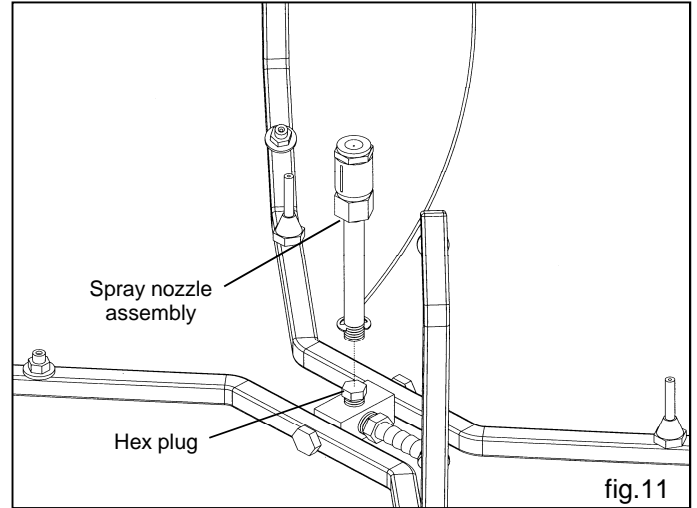

Note: Remove all gauges from any equipment being cleaned to avoid damaging the gauges.

Replace the hex plug in the manifold block when not using the spray nozzle assembly. Failure to do so will cause the gun washer to operate incorrectly.

Preventative Maintenance

- 1) Drain excess paint from cup or pot before placing in gun washer.
- 2) Drain paint sludge from gun washer tank weekly. Do this after a weekend so that it has settled. Open ball valve and drain until clear solution flows. Add cleaning solution to fill 1" above intake filter.
- 3) Remove the filter bowl and check the filter inside the regulator for excess buildup approx. every 6 months.
- 4) Change cleaning solution completely when objects being cleaned become tacky to the touch.
- 5) Clean inside of tub and intake filter before filling with cleaning solution.

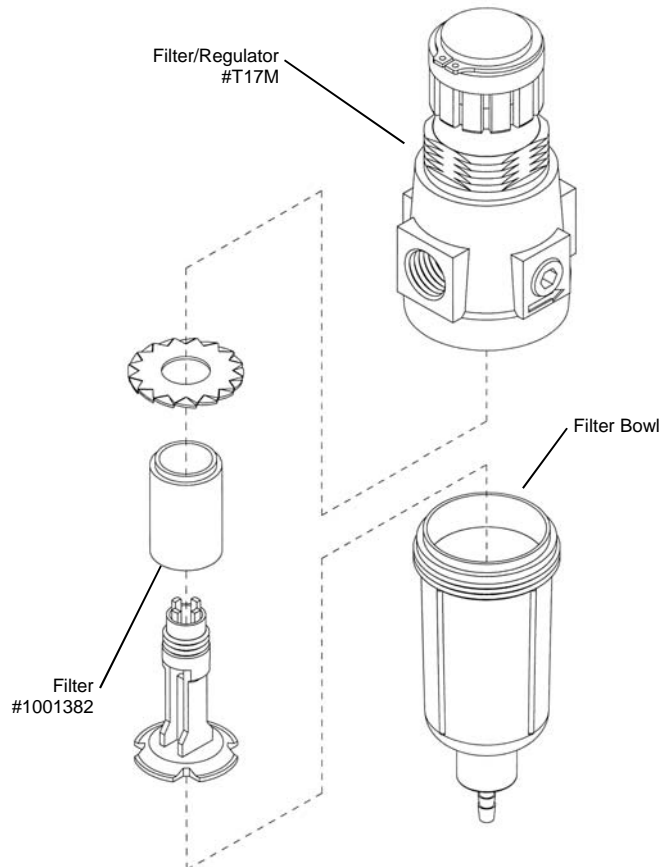

CAUTION

Do not change the setting of the filter/regulator. This could damage the filter/regulator or pump

Troubleshooting

Problem	Possible Solution
Gun washer will not turn on.	<ol style="list-style-type: none"> 1 Make sure the air line is properly connected with at least 75 psi. Air pressure is regulated at 75 psi. 2 Make sure lid is fully closed. Make sure the lid rod actuator is making full contact with the limit valve on the right rear leg. 3 Check all air connections to ensure that there are no leaks. 4 Make sure timer cam is engaging the limit valve on the right front leg. 5 Make sure timer is on and functioning correctly.
Gun washer turns on but pumps slowly or not at all.	<ol style="list-style-type: none"> 1 Make sure intake filter is not clogged (Clean or replace). 2 Make sure the air line is properly connected with at least 75 psi. Air pressure is regulated at 75 psi. 3 Check all air connections to ensure that there are no leaks. 4 Make sure there is 5 gallons of clean solution in the gun washer. The cleaning solution should be an inch above the intake filter. 5 Make sure lid is fully closed. Make sure the lid rod actuator is making full contact with the limit valve on the right rear leg. 6 Make sure manifold nozzles and stem supports are not clogged.
Gun washer will not shut off	<ol style="list-style-type: none"> 1 Make sure timer cam is moving. If its not, slightly loosen the nuts holding the limit valve on the right front leg of the stand. Reposition valve and tighten nuts. 2 Make sure limit valves located on the right front leg or right rear leg of the stand are not stuck in closed position.
Fluid does not flow through desired line, or minimal fluid flows through cleaning manifold.	<ol style="list-style-type: none"> 1 Make sure paint lines are not clogged with debris. 2 Make sure 3-way valve adjustable lever is pointing directly towards the desired port. Towards the back of the unit for internal/external cleaning of paint lines (internal cleaning portion). Towards the unit for standard manifold cleaning and for internal/external cleaning of paint lines (external cleaning portion). Towards the front of the unit for internal cleaning of paint lines.

G210 Parts Layout

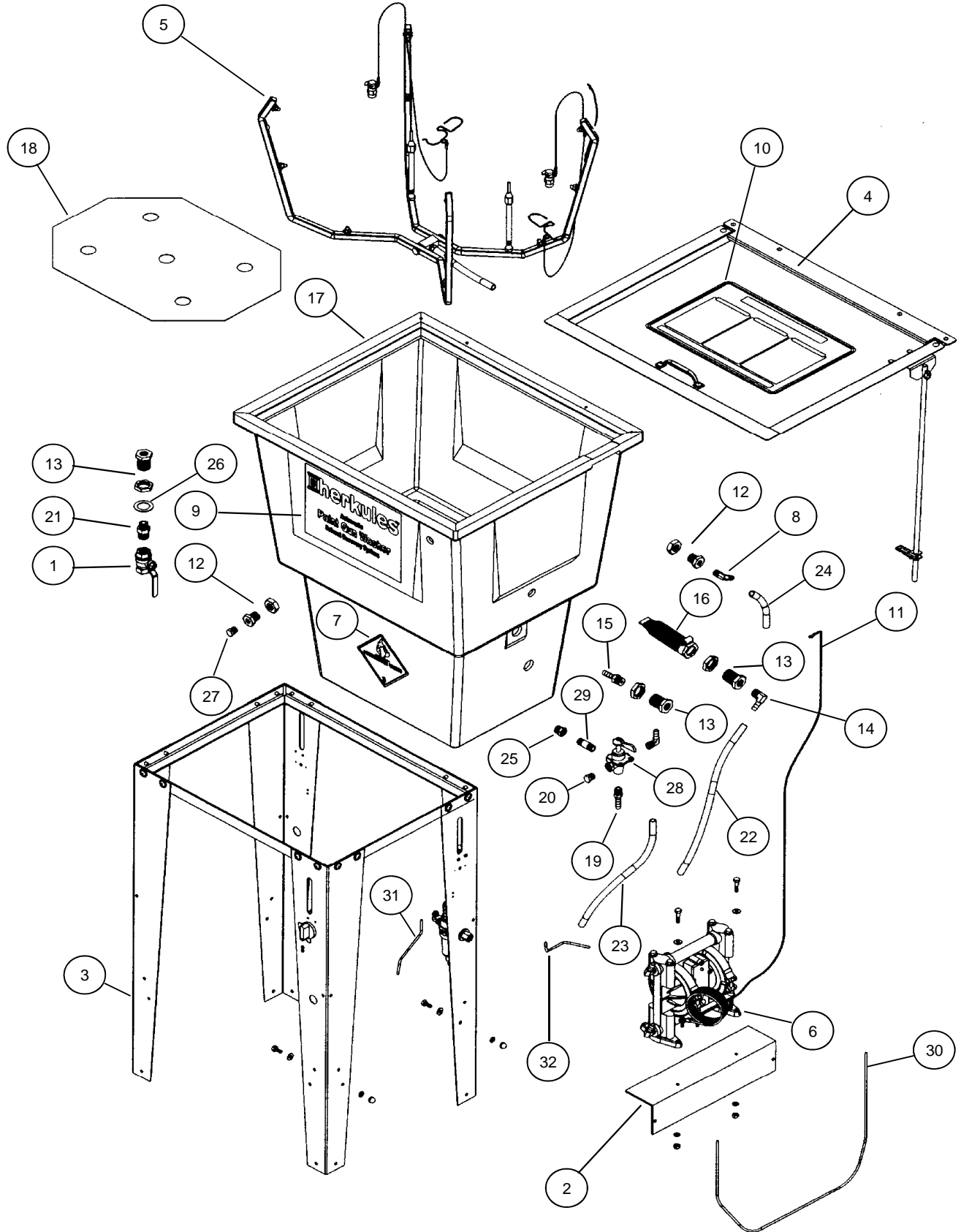

G210 Parts Layout

	Part #	Description	Quantity	
1	6	Ball Valve	1 EA.	
2	11958	Pump Mounting Bracket	1 EA.	
3	13844	Stand Assembly	1 EA.	See pg. 16
4	12025	Lid Assembly	1 EA.	See pg. 14
5	12734	Manifold Assembly	1 EA.	See pg. 15
6	12517	Pump Assembly	1 EA.	See pg. 16
7	1000651	Flammable Caution Sticker	1 EA.	
8	1000967	Hose Barb 3/8 x 1/4 NPT 90° - Brass	2 EA.	
9	1001706	Front Decal	1 EA.	
10	1001708	Lid Sticker	1 EA.	
11	002-120A-72	Ground Wire	2 EA.	
12	1002643	Bulkhead with Nut 3/4" - Brass	2 EA.	
13	1002644	Bulkhead with Nut 1" - Brass	3 EA.	
14	1002650	Hose Barb 3/8 x 3/8 NPT 90° - Brass	1 EA.	
15	1002654	Hose Barb 3/8 x 3/8 NPT - Brass	1 EA.	
16	12491	Filter for Pump Inlet	1 EA.	
17	1-BLUE	Tub	1 EA.	
18	25D	Divider	1 EA.	
19	57	Hose Barb 3/8 x 1/4 NPT - Brass	1 EA.	
20	59B	Plug Hex 1/4 NPT - Brass	1 EA.	
21	62	Reducing Nipple - Brass	1 EA.	
22	64PE	Hose Inlet	16 IN.	
23	64PE	Hose Outlet	13 IN.	
24	64PE	Hose	20 IN.	
25	66	Reducing Bushing - Brass	1 EA.	
26	85B	Washer 1-1/2 x 1 - Nylon	1 EA.	
27	993	Socket Plug 1/4 NPT - Brass	1 EA.	
28	C26	Valve 3-way 1/4 NPT - Brass	1 EA.	
29	M26A	Nipple 1/4 NPT - Brass	1 EA.	
30	M5	Tube 5/32 Plastic - Blue	30 IN.	
31	M5-BLACK	Tube 5/32 Plastic - Black	9 IN.	
32	M5-NEUTRAL	Tube 5/32 Plastic - Neutral	13 IN.	

Note: For parts shown but not identified refer to assembly layouts on pages 13-17.
For whole 3-way valve assembly ref.# 12729

G210 Lid Layout

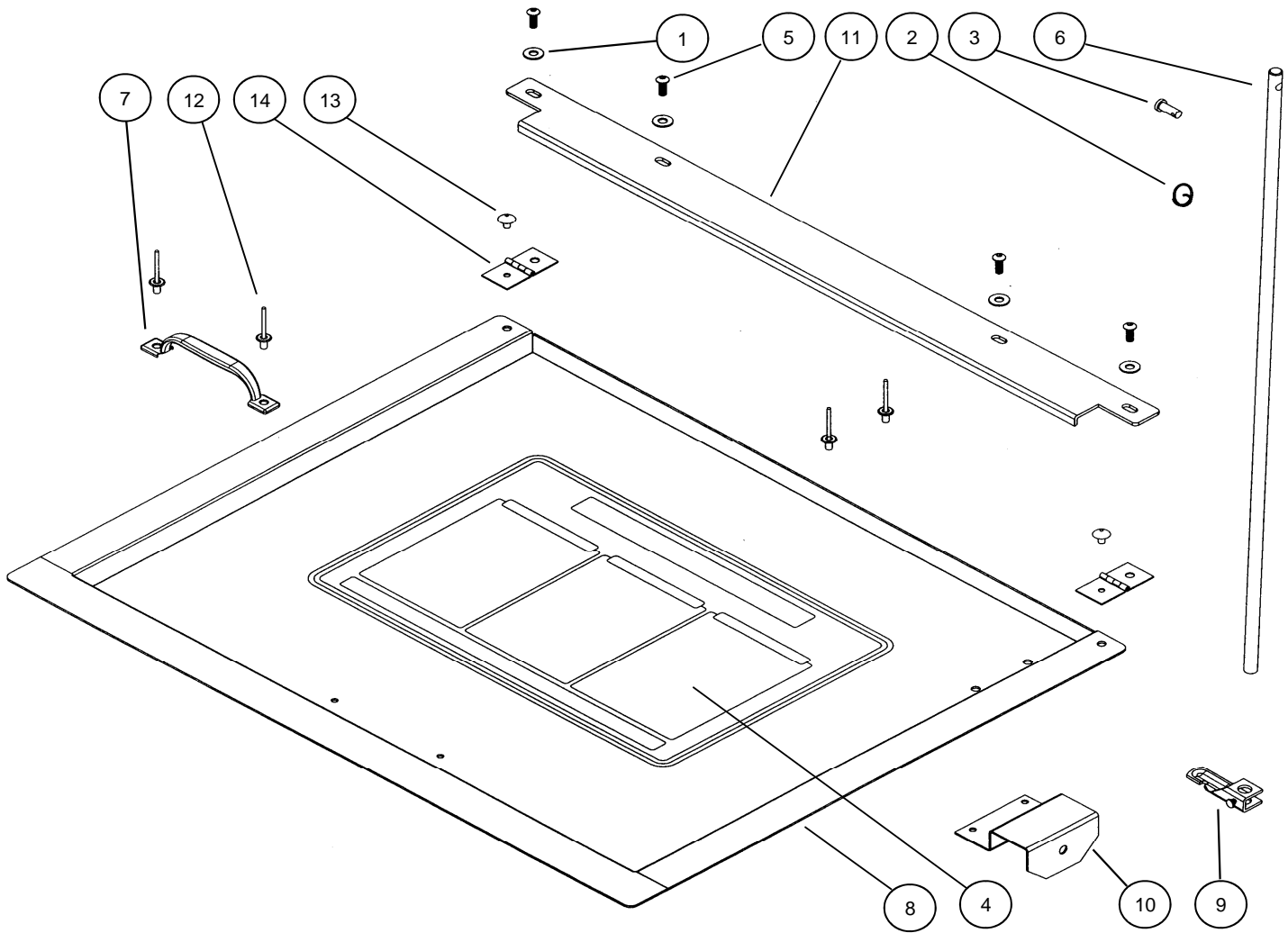

Part #	Description	Quantity
1	002-161 Washer Flat #10 USS - Zinc	4 EA.
2	1000252 Actuator Clip Ring	1 EA.
3	1000652 Actuator Pin	1 EA.
4	1001708 Lid Sticker	1 EA.
5	1002546 Screw 10-24 x 1/2	4 EA.
6	1002572 Actuator Rod	1 EA.
7	10A Handle	1 EA.
8	11219 Lid	1 EA.
9	11957 Actuator Bracket Notched	1 EA.
10	12024 Actuator Lid Bracket	1 EA.
11	12321 Lid Stop	1 EA.
12	14C Rivet 3/16 x 1/2 - Aluminum	4 EA.
13	17 Rivet 3/16 x 1/4 - Stainless	2 EA.
14	39C Hinge	2 EA.

Note: Parts are shown for reference purposes only and are not necessarily part of a Herkules assembly.

G210 Manifold Layout

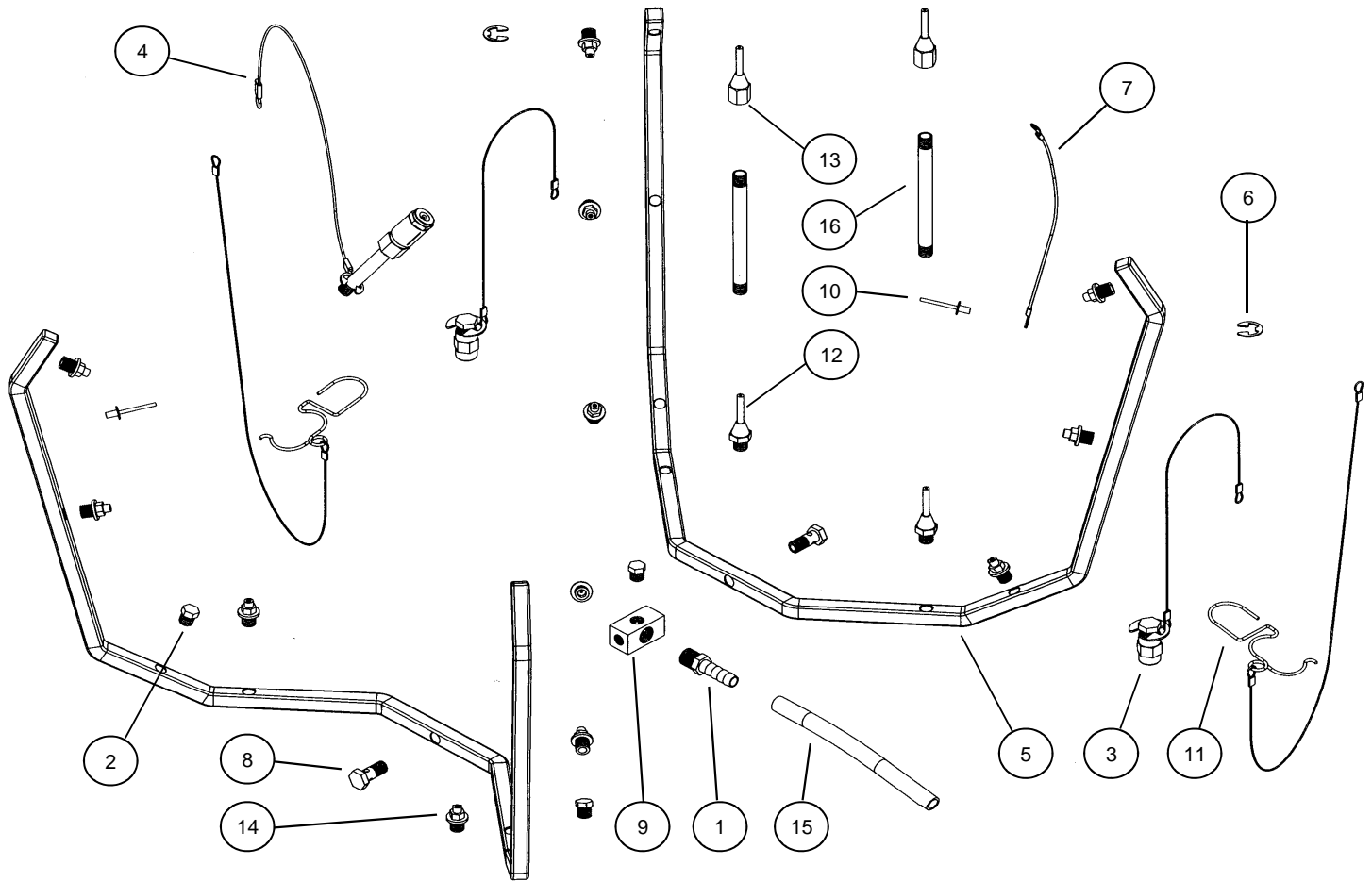

Part #	Description	Quantity
1	57 Hose Barb 3/8 x 1/4 NPT - Brass	1 EA.
2	59 Hex Plug 1/8 NPT - Brass	3 EA.
3	12509 Air Cap Assembly - Brass and Stainless	2 EA.
4	12599 Spray Nozzle Assembly	1 EA.
5	1002321 Manifold Half - Stainless	2 EA.
6	1002651 E-ring - Stainless	2 EA.
7	002-121A-6 Manifold Ground Wire	1 EA.
8	002-136S Manifold Bolt - Stainless	2 EA.
9	002-137D Manifold Block	1 EA.
10	002-192 Ground Wire Rivet	2 EA.
11	22BA Trigger Lock Assembly	2 EA.
12	53A Stem Support Male	2 EA.
13	53B Stem Support Female	2 EA.
14	54P1 Full jet Nozzle - White	12 EA.
15	64PE Manifold Hose	7 IN.
16	C9A Nipple 4-1/2" - Brass	2 EA.

Note: Parts are shown for reference purposes only and are not necessarily part of a Herkules assembly.

G210 Pump and Legs Layout

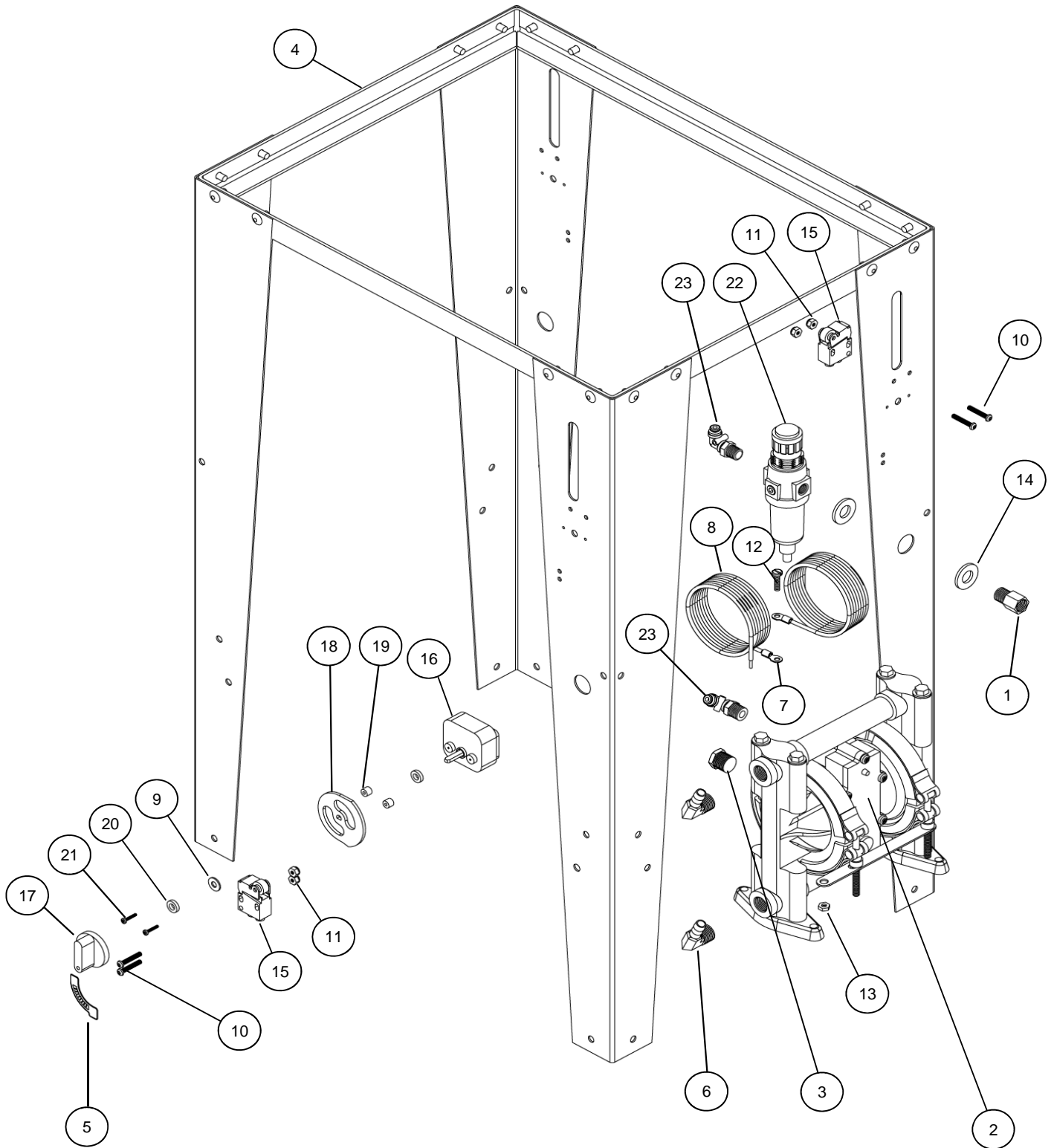

G210 Pump and Legs Layout

	Part #	Description	Quantity
1	67	Adaptor 1/4 NPT - Brass	1 EA.
2	338	Pump	1 EA.
3	1001441	Muffler	1 EA.
4	13844	Stand Assembly	2 EA.
5	1002414	ON/OFF Sticker	1 EA.
6	1002650	Hose Barb 3/8 x 3/8 NPT 90° - Brass	2 EA.
7	002-106	Wire Terminal	3 EA.
8	002-120A-72	Ground Wire	2 EA.
9	002-161	Washer Flat #10 USS - Zinc	1 EA.
10	002-171	Screw 8-32 x 1 - Black	4 EA.
11	002-172	Nut Nylock 8-32 - Zinc	4 EA.
12	005-131	Screw 10-24 x 1/2 - Stainless	1 EA.
13	005-132	Nut Hex 10-24 - Stainless	1 EA.
14	85D	Washer Flat 1/2 - Zinc	2 EA.
15	M1C	Limit Valve - Gold	2 EA.
16	M230-001A	Timer	1 EA.
17	M230-002	Knob for Timer	1 EA.
18	M230-003	Cam For Timer	1 EA.
19	M230-004	Spacer 1/4" Thick - Nylon	2 EA.
20	M230-005	Spacer 1/8" Thick - Nylon	2 EA.
21	M230-006	Timer Screw #4 x 5/8	2 EA.
22	T17M	Filter / Regulator	1 EA.
23	T25	5/32 Hose fitting 90° Swivel	2 EA.

Note: Parts are shown for reference purposes only and are not necessarily part of a Herkules assembly.

G210 Hardware Layout

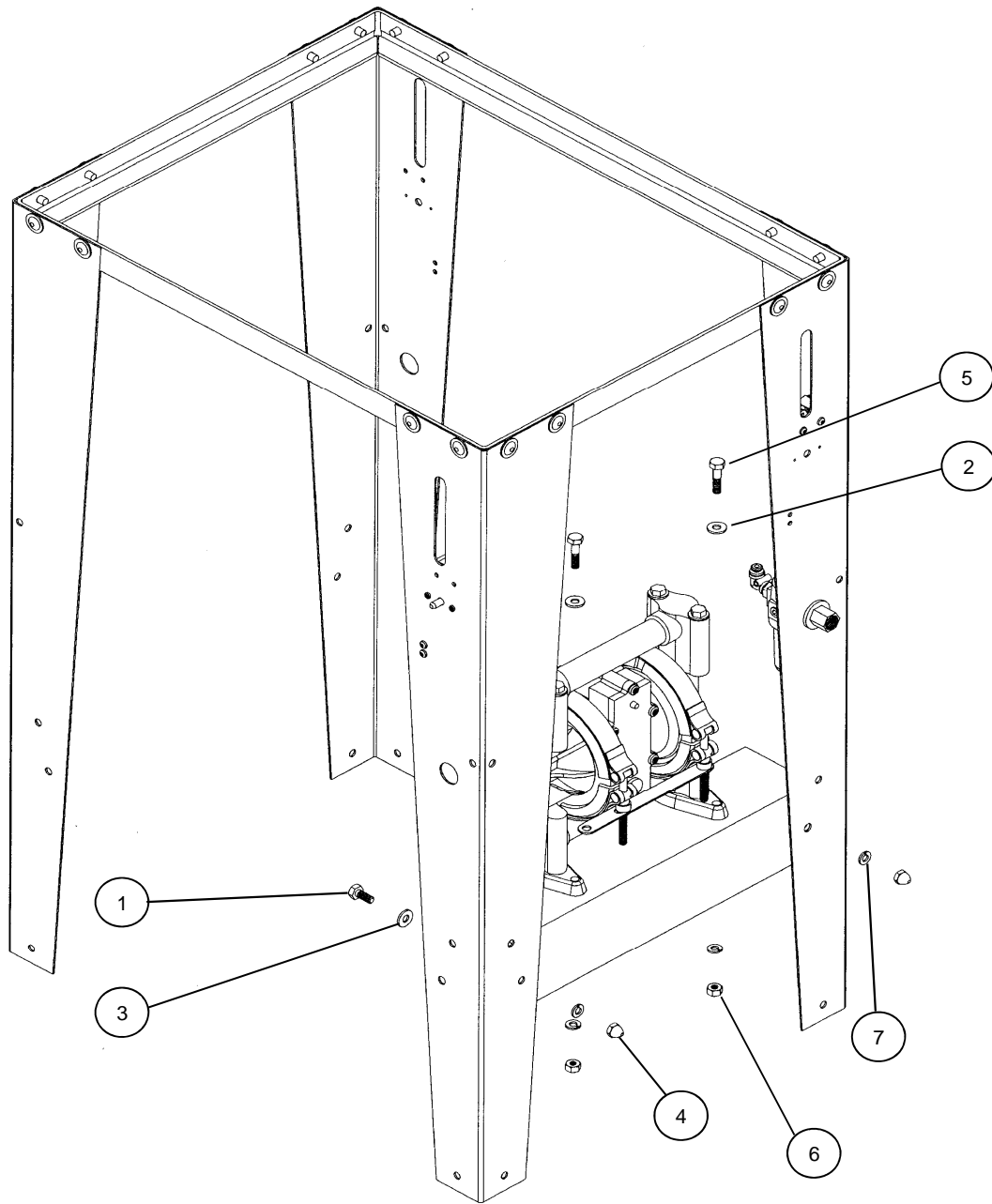

	Part #	Description	Quantity
1	001-702	Bolt Hex 1/4-20 x 1/2 - Zinc	2 EA.
2	001-705	Washer Flat 1/4 USS - Zinc	2 EA.
3	002-161	Washer Flat #10 USS - Zinc	2 EA.
4	008-244	Acorn Nut 1/4-20 - Nickel	2 EA.
5	83	Bolt Hex 1/4-20 x 1 - Zinc	2 EA.
6	84	Nut Hex 1/4-20 - Zinc	2 EA.
7	85	Washer Lock 1/4 - Zinc	4 EA.

