

G202



Made in USA

OWNERS MANUAL



This manual contains important information concerning the installation and operation of the gun washers listed above. **Read manual thoroughly and keep for future reference**

INSTRUCTIONS



Herkules Patent Numbers

These products have patent protection under one or more of the following patent numbers:

9422142, 8733508, 8714524, 866247, 8052120, 7070167, 5485860, 5193561, 5174317, 4960142, 4793369 and Patents Pending

Website: www.herkules.us
E-mail: info@herkules.us

Herkules Equipment Corporation
2760 Ridgeway Court
Walled Lake, MI 48390-1662 USA

Toll Free: 800-444-4351
Phone: 248-960-7100
Fax: 248 960-7109

Table of Contents

Warranty	3
Model Information	4
Warnings	5-6
Assembly Instructions	7
Installation	8
Operation	9
Preventative Maintenance	10
Troubleshooting	11
Drawings with Part Lists	12-20
G202 Schematic	21

Herkules Equipment Corporation

A U.S.-based manufacturer, Herkules Equipment Corporation offers a diverse line of products that support multiple industries by improving efficiency, productivity, ergonomics, comfort, and safety in the work environment. The company consists of the three product lines: Herkules, Enkon and BossLifts.

Since 1985, Herkules has designed, engineered and manufactured quality products at our Walled Lake, Michigan facility. Our company supports our products after delivery, with U.S. based customer service, and replacement parts, enabling our customers to proceed with confidence.

To learn more about Herkules, visit <http://herkules.us>. Contact us at info@herkules.us with any questions or concerns.

Thank you for purchasing a Herkules product!

Warranty

IMPORTANT NOTICE: if you have a problem with your Herkules product,

DO NOT RETURN TO PLACE OF PURCHASE

Contact Herkules: by phone 1-800-444-4351; by email, info@herkules.us; or on the web at herkules.us/contact-us.

At Herkules we take great pride in the construction of our American-made products, and we stand behind their reliability. Our limited liability warranty coverage for Paint Gun Washers warranties the unit for a period of 12 months. Washer pumps have a separate warranty; the Herkules 338 pump is protected for a period of 2 years from the date of purchase. All other pumps, including rinse pumps, are warranted for 12 months.

This warranty does not apply to equipment damaged from accident, abuse, overload, misuse, negligence, improper installation, abrasive or corrosive materials, or shipping damage.

In the event of product failure, the defective item must be returned, freight prepaid, to the Herkules manufacturing plant for repair or replacement. If repairs are required, Herkules will not be liable for these repairs to take place in the field regardless of the application. Proof of purchase and date of purchase must be confirmed. An RGA* (Returned Goods Authorization) and written approval from Herkules must be obtained before any goods can be shipped to Herkules. We reserve the right to Determine whether failure is due to defective material, normal wear, and / or other causes.

There are no warranties which extend beyond the description on the face hereof. Herkules disclaims any warranty of merchantability or fitness for a particular purpose in connection with the Buyer's purchase of any Product under this agreement. Damages are limited to the sales price of the Herkules system. The terms and conditions herein represent the entire agreement between Herkules and the Buyer. Any prior / future representations do not apply.

*To obtain a RGA, contact Herkules at 1-800-444-4351 and have the item model, serial numbers, and invoice number if applicable.

Upon receipt of your equipment, please write your purchase information below. Please retain this manual for your records.

Serial Number _____ Model Number _____

Purchase Date _____ Distributor (if applicable) _____

Parts bag contents

Model Information

Part #	Description	Quantity
53B	Stem Support Female	2 ea.
C9A	Nipple 1/8 NPT x 4-1/2 Brass	2 ea.
M5	Tube 5/32 Blue	30 in.
M5-Black	Tube 5/32 Black	4.5 in.
M5-Black	Tube 5/32 Black	4.5 in.
1002759	Owner's Manual	1 ea.
005-137	Nut Nylock 10-24 Z	1 ea.
1000252	Cotter Ring	2 ea.
1000652	Clevis Pin 1/4 x 5/8 Z	2 ea.
1001109	Plug 1/2-16-18 Black	1 ea.
1001110	Screw SHLD 1/4 x 5/8 x 10-24 H/T ST	1 ea.
11957	Actuator Notched for GWR	1 ea.
002-161	Washer Flat .252ID x .5625 OD x .045	4 ea.
M230-005	Spacer .500 x .257ID x .125 Nylon	1 ea.

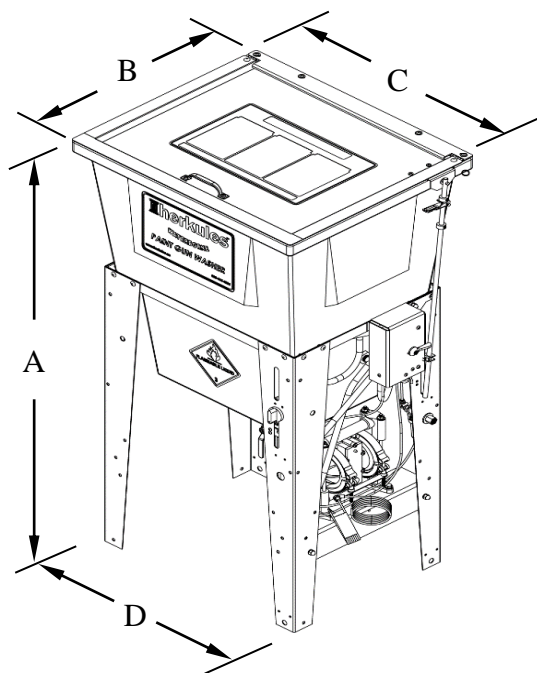

NOTE: Dimensions listed are overall measurements.

Model	Description	Weight lbs/(kg)	Dimensions in./(mm)			
			A	B	C	D
G202	Two gun, two cup paint gun washer equipped with diaphragm pump, filter-regulator, timer, manual brush clean for solvent or water based paints.	68 (31)	46.25 (1175)	22.6 (574)	25 (635)	21.25 (635)

Warning Symbol



This symbol alerts you to the possibility of serious injury or death if you do not follow the instructions.

Caution Symbol



This symbol alerts you to the possibility of damage to or destruction of equipment if you do not follow the instructions.



WARNING



EQUIPMENT MISUSE HAZARD

Equipment misuse can cause the equipment to rupture, malfunction, or start unexpectedly and result in serious injury.

- This equipment is for professional use only.
- Read all instruction manuals, tags, and labels before operating the equipment.
- Use the equipment only for its intended use.
- Do not alter or modify this equipment.
- Do not exceed the maximum working pressure of the lowest rated system component.
- Do not operate the gun washer at a pressure above the maximum working pressure rating of the gun(s) being cleaned.
- Route the hoses away from traffic areas, sharp edges, moving parts, and hot surfaces.
- Do not use the hoses to pull the equipment.
- Do not move pressurized equipment.
- Use fluids or solvents that are compatible with the equipment wet parts. Read the fluid and solvent manufacturer's warnings.
- Comply with all applicable local, state and national fire, electrical and other safety regulation.



PRESSURIZED EQUIPMENT HAZARD

Spray from hose leaks, ruptured components, or from operating the gun washer with an open lid can splash fluid in the eyes or on the skin and cause serious injury.

- A safety device has been installed to shut off the pump when the gun washer lid is opened.
Do not tamper with, or alter, this device.
- Open the gun washer lid slowly.
- Do not prop the gun washer lid open with an object or by any other means.
- Do not stop or deflect fluid leaks with your hand, body, glove, or rag.
- Tighten all fluid connections before operating the equipment.
- Replace worn, damaged, or loose parts immediately.



WARNING



FIRE AND EXPLOSION HAZARD



Improper grounding, poor air ventilation, open flames, or sparks can cause a hazardous condition and result in fire or explosion and serious injury.

- Ground the equipment. See Installation section (page 8) for grounding procedure.
- Provide fresh air ventilation to avoid the build up of flammable fumes from the cleaning solution.
- Extinguish all open flames or pilot lights in the gun washer area.
- Disconnect all electrical equipment in the gun washer area.
- Keep the gun washer area free of debris, including cleaning solutions, rags, and gasoline.
- Do not turn on any light switch in the gun washer area while operating or if fumes are present.
- Do not smoke in the gun washer area.
- Do not operate a gasoline engine in the gun washer area.
- Follow the gun manufacturer's solvent and other cleaning recommendations.
- Use solvent with the highest possible flash point.
- If there is any static sparking while using the equipment, **stop operation immediately**. Identify and correct the problem.
- Drain the cleaning solution into a proper storage container when gun washer(s) is not in use.



TOXIC FLUID HAZARD

Hazardous fluids or toxic fumes can cause serious injury or death if splashed in eyes or on the skin, swallowed, or inhaled.

- Know the specific hazards of the fluid you are using. Read the fluid manufacturer's warnings.
- Store hazardous fluid in an approved container. Dispose of hazardous fluid according to all local, state and national guidelines.
- Wear the appropriate protective clothing, gloves, eyewear and respirator.
- Pipe and dispose of the exhaust air safely. If diaphragm fails, the fluid may be exhausted along with the air.

Assembly Instructions

Connecting lid rod and actuator linkage

STEP 1

Attach the lid rod to the lid bracket using the 1/4" clevis pin and circular cotter pin supplied [see fig.1].

NOTE: The lid rod installs to the back side of the lid bracket.

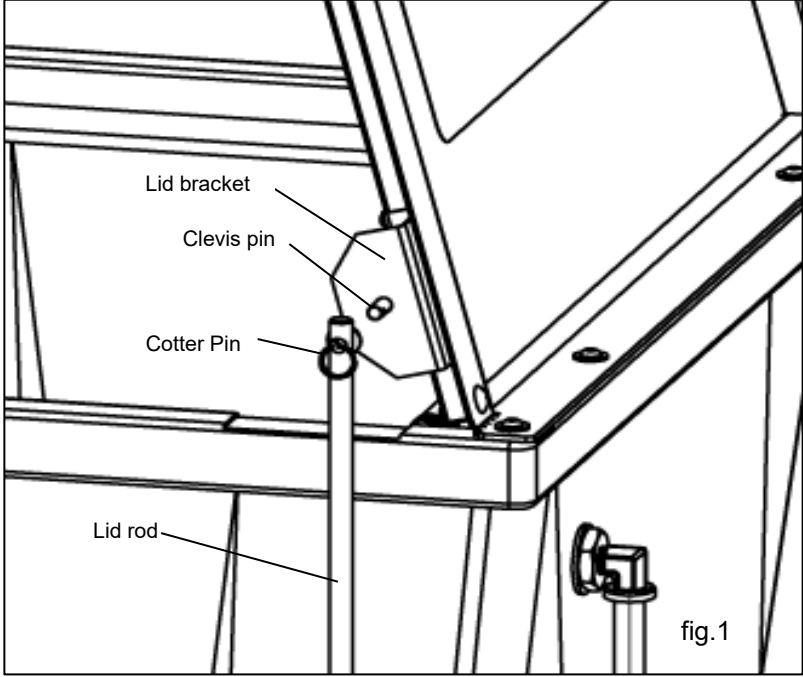

Grounding the lid

STEP 2

Verify ground wire is attached as shown [see fig. 2].

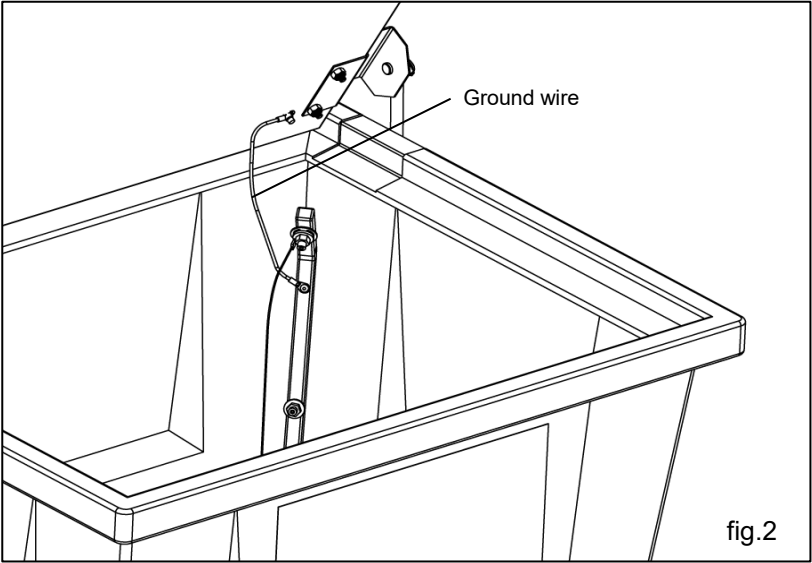

Installation

Installing the Gun Washer

- 1) Place gun washer on a level surface in a properly ventilated paint mixing room or paint booth.

Grounding the Gun Washer

- 1) Connect the ground wire on the gun washer's pump to a true earth ground.
- 2) Ground all equipment used or located in the gun washer area.

Connecting the Air Line

- 1) Install a 1/4 in. npt male coupler, that is compatible with the quick disconnect of your air supply line, into the air supply port of the filter/regulator located on the right rear leg [see fig.3].
- 2) Connect air line with at least 75 psi to the coupler. Filter/regulator is preset. Do not adjust.

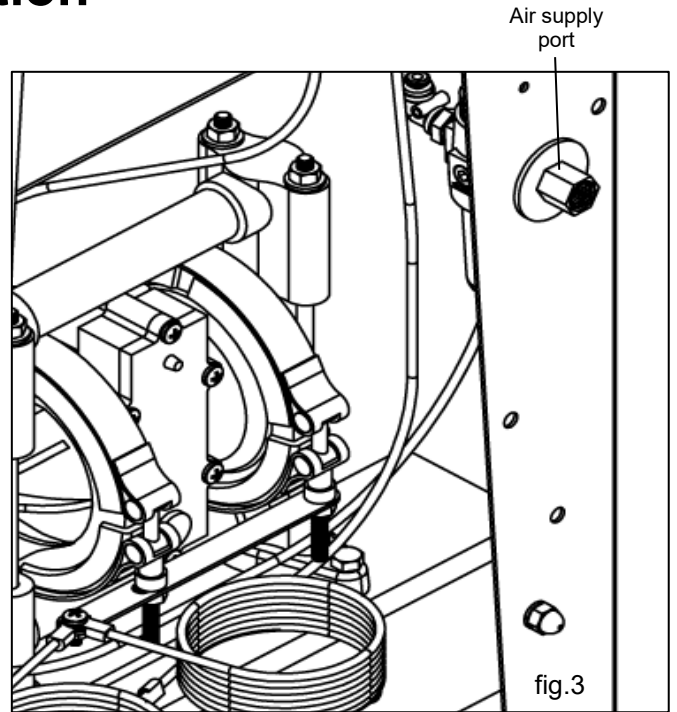

Operation

Filling the Gun Washer with Fluid

- 1) Close ball valve located on the bottom of the tank.
- 2) Pour five gallons (18.9 liters) of high quality cleaning solution into the tub. Unit is capable of cleaning exclusively either solvent or water based paints.

Preparing the Equipment to be washed

- 1) Remove paint cup or paint line and the air line from the paint gun.
- 2) Drain excess paint from cup and gun.
- 3) Remove all gauges and regulators.
- 4) Lock the gun trigger in the open position by placing the trigger lock around the gun handle and trigger [see fig.3].

CAUTION

All pressure gauges must be removed before placing the equipment in the gun washer to avoid damaging the gauges.

Placing Equipment in the Gun Washer

To clean guns not mentioned here, use the long or short stem supports as needed [see fig.4]. For questions or adapter kits contact your paint gun washer distributor.

Siphon Feed Guns

Place the gun siphon tube on the short stem support.

Gravity Feed Guns (HVLP)

Place long stem support over one of the short stem supports. Place paint inlet of gun on long stem support. Place the air cap assembly over the air inlet of the gun to keep cleaning solution out.

Pressure Feed Guns

Place long stem support over one of the shorter stem supports. Place paint inlet of gun on long stem support.

Pots and Cups

Place pots and/or cups on divider platform over front spray nozzles.

fig.4

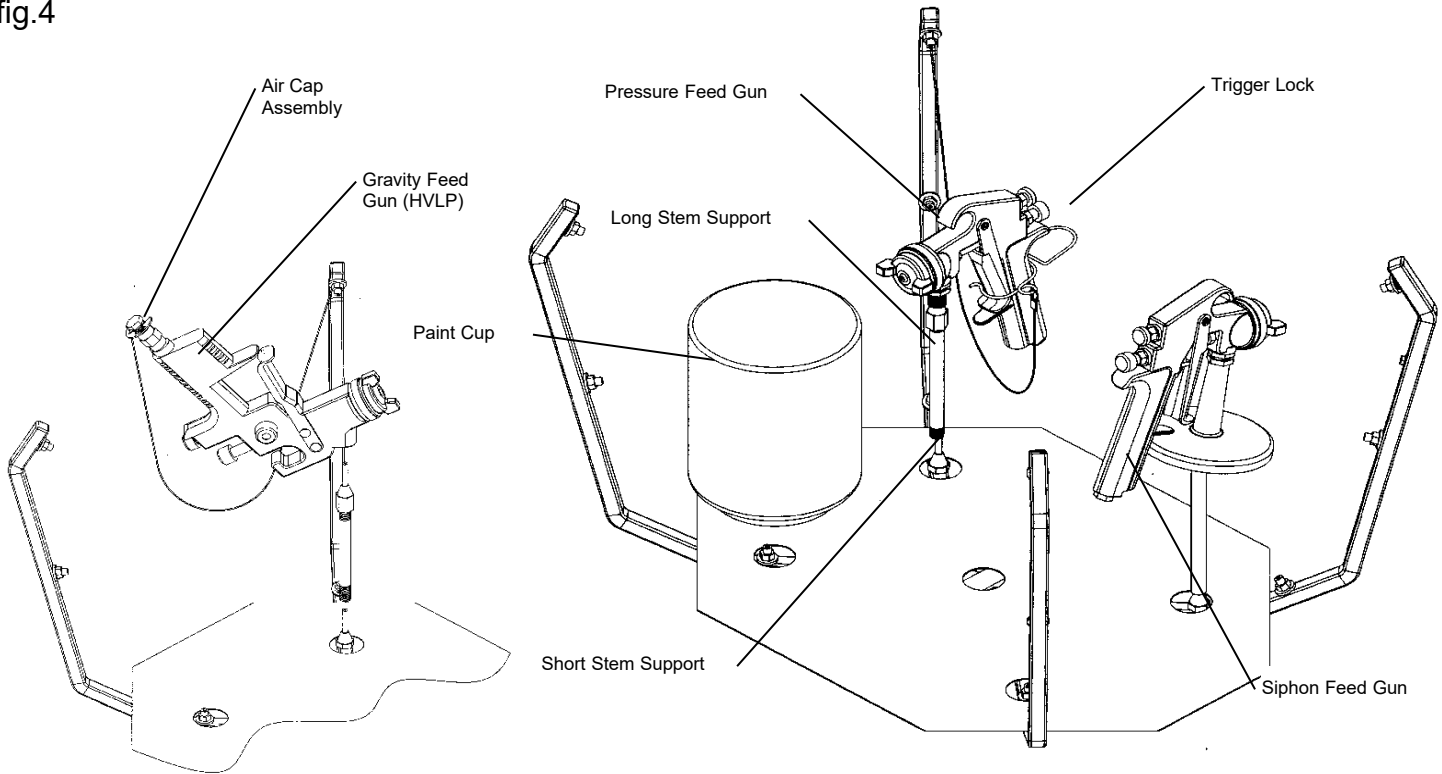

Operation

Operating the Gun Washer

- 1) Make sure all wire trigger locks and other accessories are inside the gun washer tub.
- 2) If washing only one set of equipment, place empty cans over the unused nozzles and/or stem supports to prevent spray from hitting the underside of the gun washer lid.
- 3) Close the gun washer lid.
- 4) Turn the timer knob clockwise 90 degrees to start the gun washer. The gun washer will run for 90 seconds. Turning the timer knob less than 90 degrees will reduce the timing cycle. Paint equipment will clean in 60 to 90 seconds.
- 5) If the lid is opened prior to the end of the timing cycle, the safety air cutoff switch will stop the gun washer. The gun washer will start again when the lid is closed if time remains on the timer.

Note: Open the lid slowly to minimize vapor escape.

- 6) Remove the equipment from the gun washer and wipe off any remaining cleaning solution.

Operating the Manual Brush

- 1) Make sure timer is turned off.
- 2) Prop open the lid with the Lid Prop and place equipment to be cleaned inside the gun washer.
- 3) Hold brush so that the bristles point downward inside the gun washer.
- 4) Turn the lever on the valve assembly to the 'Brush Clean' position.

Note: DO NOT turn on timer. Brush operates without the timer controls.

- 5) To increase the flow through the brush, turn the knob of the flow control valve counterclockwise. To decrease the flow through the brush, turn the knob of the flow control valve clockwise.
- 6) Clean parts as necessary, and when finished, remove lid prop so lid will close.
- 7) Turn the lever on the valve assembly to the 'Auto Clean' position.

Note: The brush will continue supplying fluid until the lever is returned to the 'Auto Clean' position.

Preventative Maintenance

To keep your machine working efficiently, please follow these directions.

- 1) ALWAYS drain excess paint from cup or pot before placing in gun washer.
- 2) Drain paint sludge from gun washer tank weekly. Do this after a weekend so that it has settled. Open ball valve and drain until clear solution flows. Add cleaning solution to fill 1" above intake filter.
- 3) Replace Filter/Regulator yearly. (#11345)
- 4) Change cleaning solution completely when objects being cleaned become tacky to the touch.
- 5) Clean inside of tub and intake filter before filling with cleaning solution.

CAUTION

Do not change the setting of the filter/regulator. This could damage the filter/regulator or pump

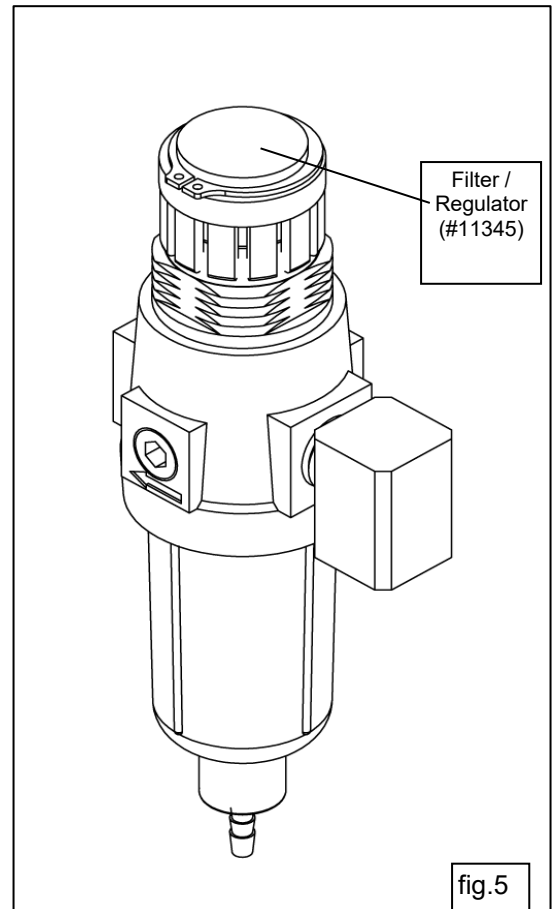

Troubleshooting

Problem	Possible Solution
Gun washer will not turn on.	<ol style="list-style-type: none"> 1 Make sure the air line is properly connected with at least 75 psi. Air pressure is regulated at 75 psi. 2 Make sure lid is fully closed. Make sure the lid rod actuator is making full contact with the limit valve on the right rear leg. 3 Check all air connections to ensure that there are no leaks. 4 Make sure timer cam is engaging the limit valve on the right front leg. 5 Make sure timer is on and functioning correctly. 6 Make sure brush valve is turned to the 'Auto Clean' position for automatic cleaning or 'Brush Clean' for manual brush cleaning.
Gun washer turns on but pumps slowly or not at all.	<ol style="list-style-type: none"> 1 Make sure intake filter is not clogged (Clean or replace). 2 Make sure the air line is properly connected with at least 75 psi. Air pressure is regulated at 75 psi. 3 Check all air connections to ensure that there are no leaks. 4 Make sure there is 5 gallons of clean solution in the gun washer. The cleaning solution should be an inch above the intake filter. 5 Make sure lid is fully closed. Make sure the lid rod actuator is making full contact with the limit valve on the right rear leg. 6 Make sure manifold nozzles and stem supports are not clogged. 7 Make sure brush valve is facing exactly in the desired direction.
Gun washer will not shut off	<ol style="list-style-type: none"> 1 Make sure timer cam is moving. If its not, slightly loosen the nuts holding the limit valve on the right front leg of the stand. Reposition valve and tighten nuts. 2 Make sure limit valves located on the right front leg or right rear leg of the stand are not stuck in closed position. 3 Make sure brush valve is not turned to the 'Brush Clean' position. 4 Make sure limit valve inside brush valve is not stuck in closed position.

G202 Parts Layout

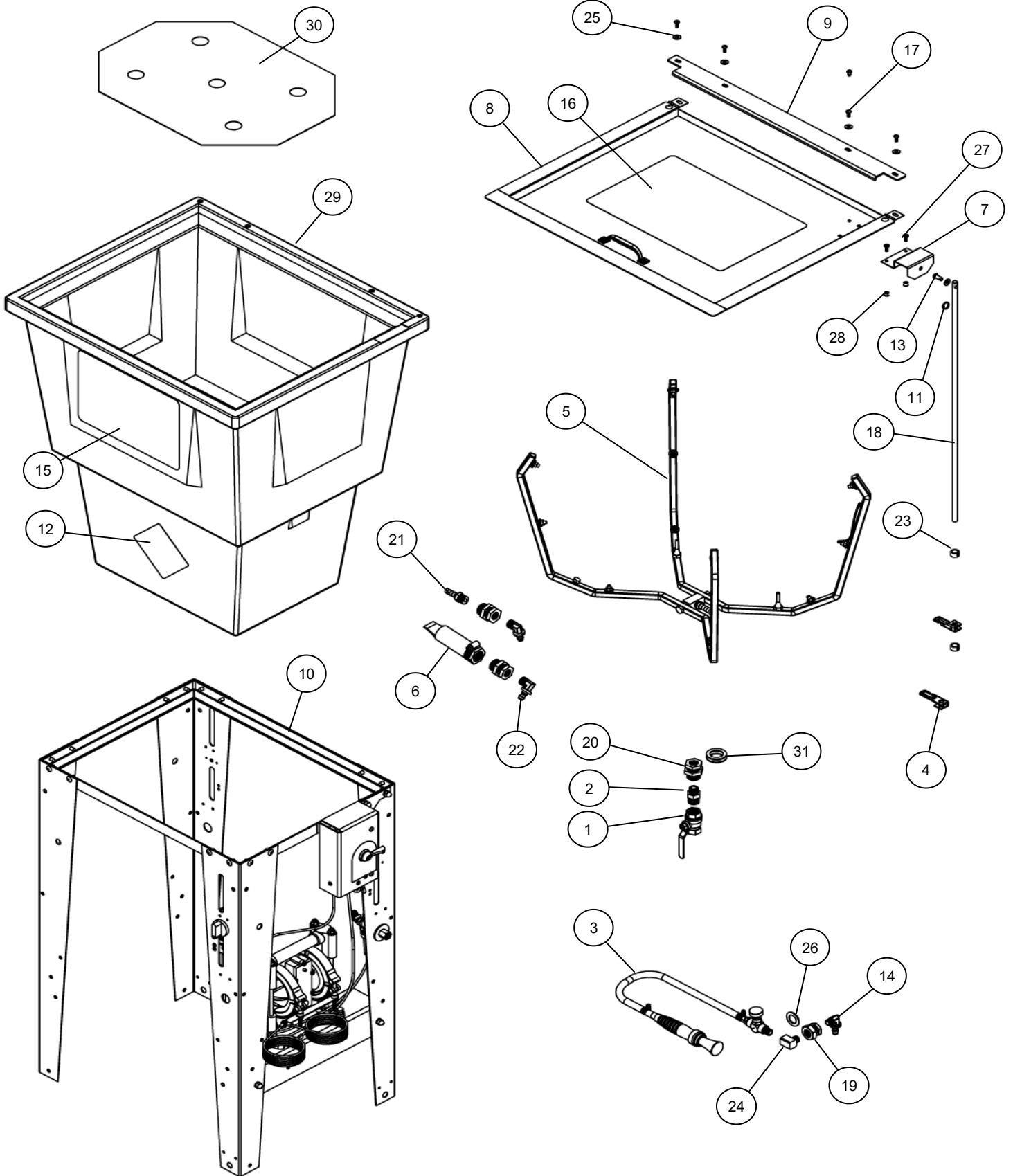

G202 Parts Layout

	Part #	Description	Quantity
1	6	Ball Valve	1 EA.
2	62	Reducing Nipple - Brass	1 EA.
3	10737	Manual Brush Assembly	1 EA.
4	11957	Actuator	2 EA.
5	12490	Manifold Assembly	1 EA.
6	12491	Filter for Pump Inlet	1 EA.
7	12024	Lid Bracket	1 EA.
8	19196	Lid Assembly	1 EA.
9	12321	Lid Stop	1 EA.
10	13892	Stand Assembly	1 EA.
11	1000252	Cotter Pin	1 EA.
12	1000651	Flammable Caution Sticker	1 EA.
13	1000652	Clevis Pin	1 EA.
14	1000967	Hose Barb 90° 3/8 x 1/4 NPT Brass	1 EA.
15	1003048	Front Decal	1 EA.
16	1001708	Lid Sticker	1 EA.
17	1002546	Screw BHSC 10-24 x 1/2	4 EA.
18	1002572	Actuator Rod	1 EA.
19	1002643	Bulkhead with Nut 3/4" - Brass	1 EA.
20	1002644	Bulkhead with Nut 1" - Brass	3 EA.
21	1002654	Hose Barb 3/8 x 3/8 NPT - Brass	1 EA.
22	1002650	Hose Barb 90° 3/8 x 3/8 NPT Brass	2 EA.
23	1004740	Collar 3/4 OD x 3/8 ID	2 EA.
24	002-131	Elbow Street 1/4 NPT Brass	1 EA.
25	002-161	Washer Flat #10 USS Zinc	4 EA.
26	005-103	Washer 3/4" - Nylon	1 EA.
27	005-131	Screw PHM Phil 10-24 x 1/2 SS	2 EA.
28	005-137	Nut Nylock 10-24 Zinc	2 EA.
29	19319	Tub	1 EA.
30	25D	Divider	1 EA.
31	85B	Washer 1-1/2 x 1 - Nylon	1 EA.

Note: Parts are shown for reference purposes only and are not necessarily part of a Herkules assembly.

G202 Manifold Layout

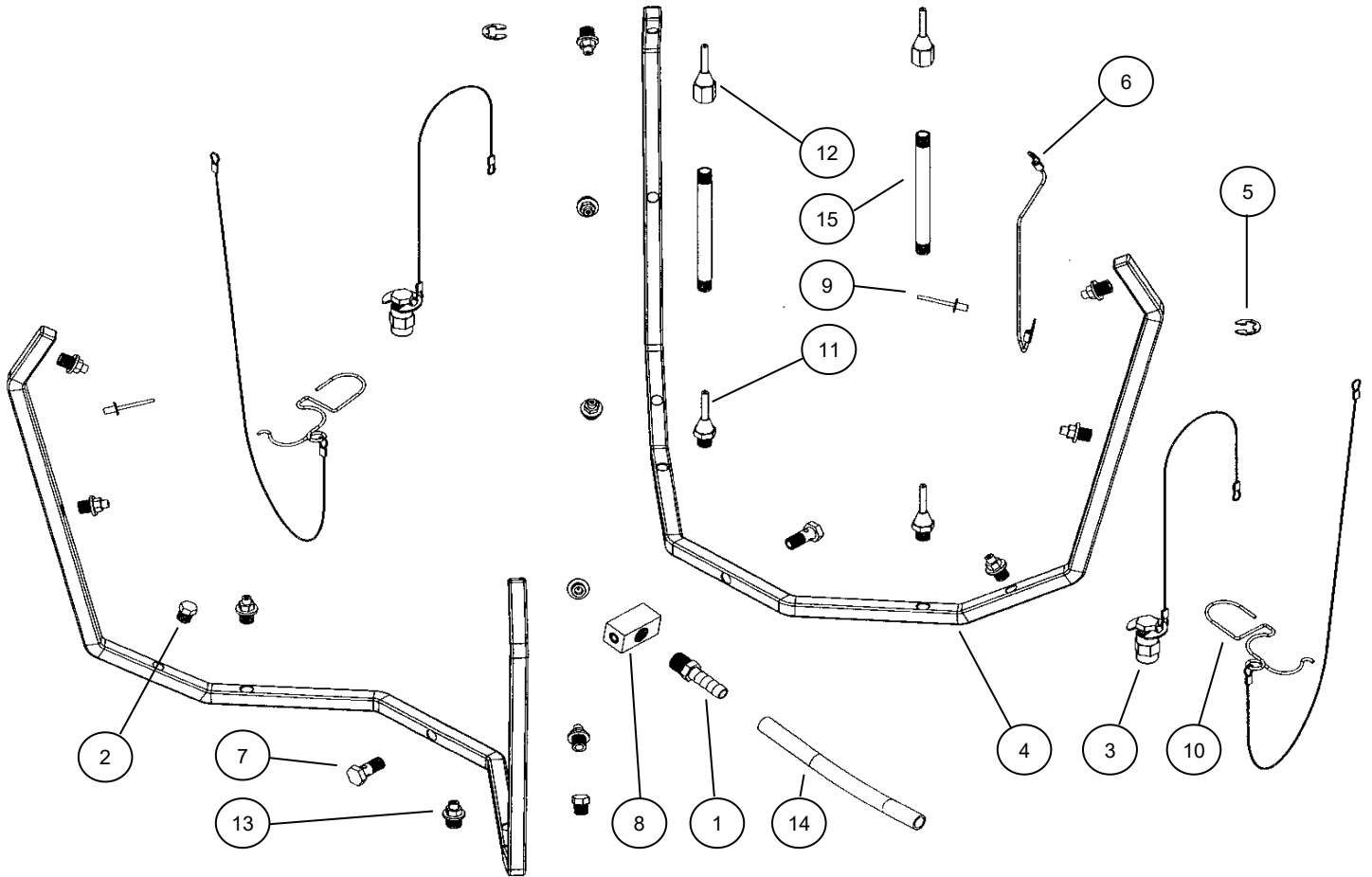

Part #	Description	Quantity	
1	57	Hose Barb 3/8 x 1/4 NPT - Brass	1 EA.
2	59	Hex Plug 1/8 NPT - Brass	2 EA.
3	12509	Air Cap Assembly - Brass and Stainless	2 EA.
4	1002321	Manifold Half - Stainless	2 EA.
5	1002651	E-ring - Stainless	2 EA.
6	002-121A-6	Manifold Ground Wire	1 EA.
7	002-136S	Manifold Bolt - Stainless	2 EA.
8	002-137	Manifold Block	1 EA.
9	002-192	Ground Wire Rivet	2 EA.
10	22BA	Trigger Lock Assembly	2 EA.
11	53A	Stem Support Male	2 EA.
12	53B	Stem Support Female	2 EA.
13	54P1	Full jet Nozzle - White	12 EA.
14	64PE	Manifold Hose	7 IN.
15	C9A	Nipple 4-1/2" - Brass	2 EA.

Note: Parts are shown for reference purposes only and are not necessarily part of a Herkules assembly.

G202 Stand Assembly Layout

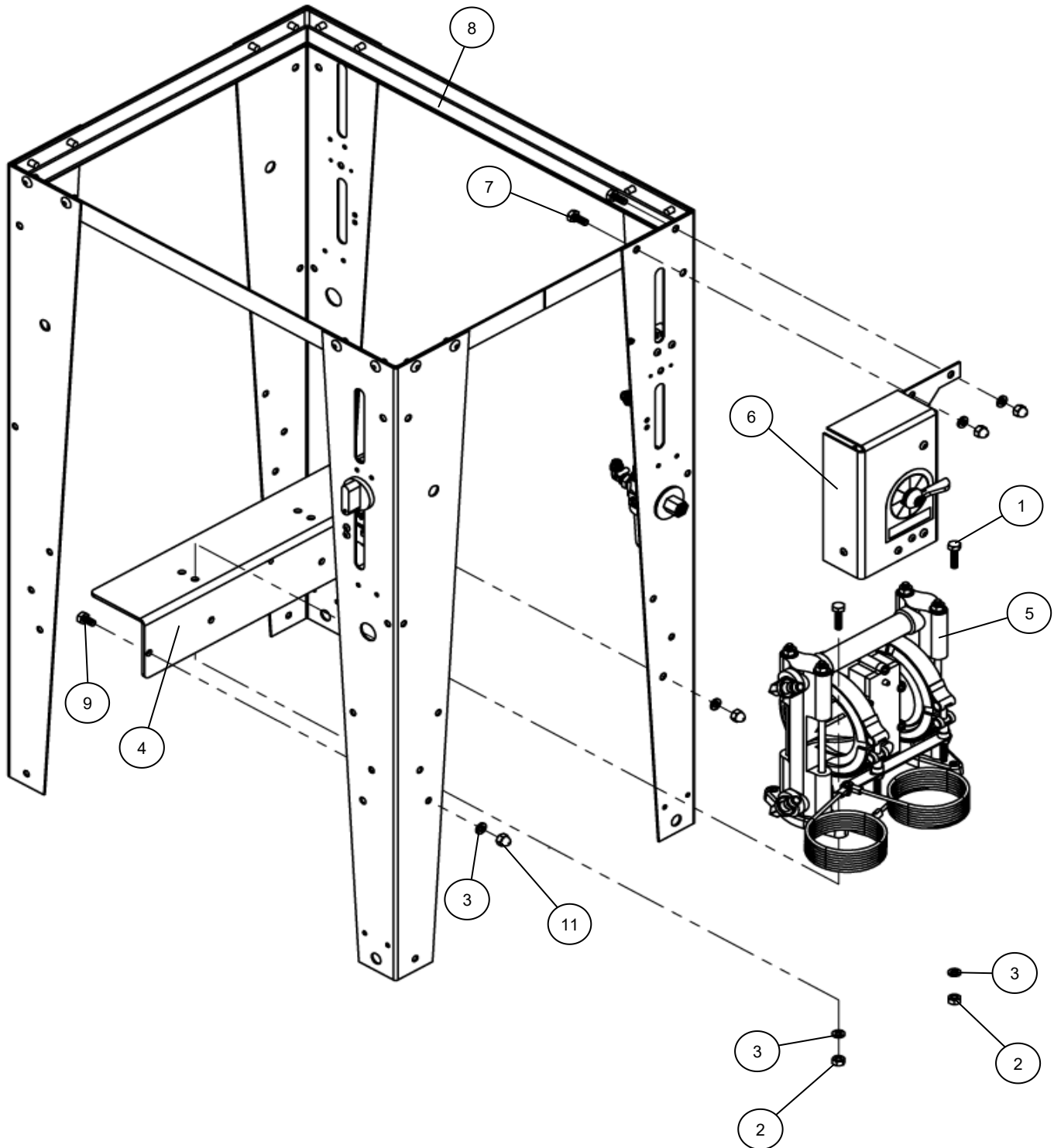

G202 Stand Assembly Layout

	Part #	Description	Quantity
1	83	Bolt Hex Full 1/4-20 x 1 Zinc	2 EA.
2	84	Nut Hex 1/4-20 Zinc	2 EA.
3	85	Washer Lock 1/4 Zinc	6 EA.
4	11958	Pump Bracket	1 EA.
5	13061	Pump Assembly	1 EA.
6	12663	Valve Assembly	1 EA.
7	1000116	Bolt Hex 1/4-20 x 5/8 Zinc	2 EA.
8	13892	Stand Assembly for G202	1 EA.
9	001-702	Bolt Hex 1/4-20 x 1/2 Zinc	2 EA.
11	008-244	Nut Acorn 1/4-20 Nickel	4 EA.

Note: Parts are shown for reference purposes only and are not necessarily part of a Herkules assembly.

G202 Legs Layout

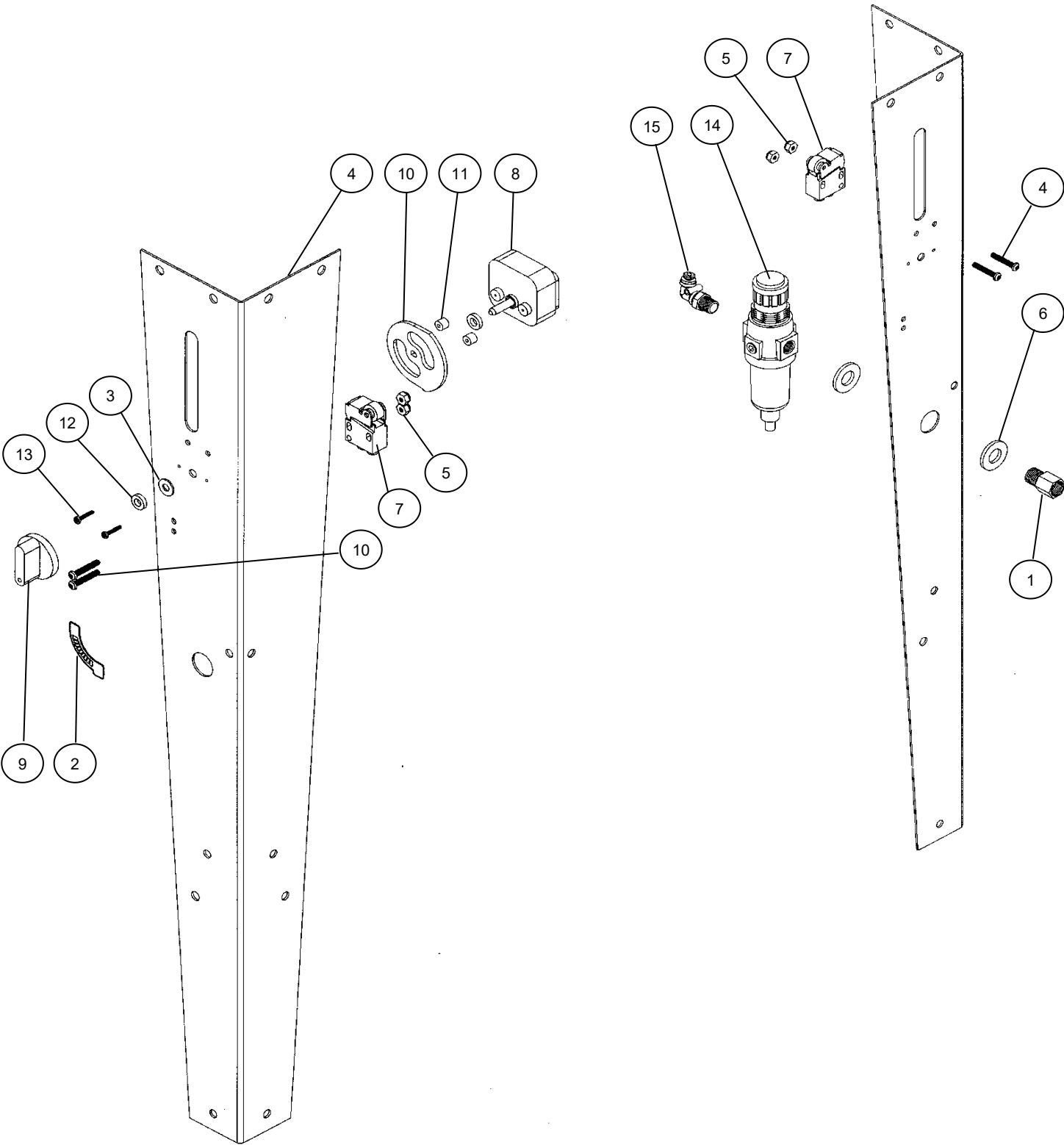

G202 Legs Layout

	Part #	Description	Quantity
1	67	Adaptor 1/4 NPT - Brass	1 EA.
2	1002414	ON/OFF Sticker	1 EA.
3	002-161	Washer Flat #10 USS - Zinc	1 EA.
4	002-171	Screw 8-32 x 1 - Black	4 EA.
5	002-172	Nut Nylock 8-32 - Zinc	4 EA.
6	85D	Washer Flat 1/2 - Zinc	2 EA.
7	M1C	Limit Valve - Gold	2 EA.
8	M230-001A	Timer	1 EA.
9	M230-002	Knob for Timer	1 EA.
10	M230-003	Cam For Timer	1 EA.
11	M230-004	Spacer 1/4" Thick - Nylon	2 EA.
12	M230-005	Spacer 1/8" Thick - Nylon	2 EA.
13	M230-006	Timer Screw #4 x 5/8	2 EA.
14	11345	Filter / Regulator	1 EA.
15	T25	5/32 Hose Fitting 90° Swivel	2 EA.

Note: Parts are shown for reference purposes only and are not necessarily part of a Herkules assembly.

G202 Valve Layout

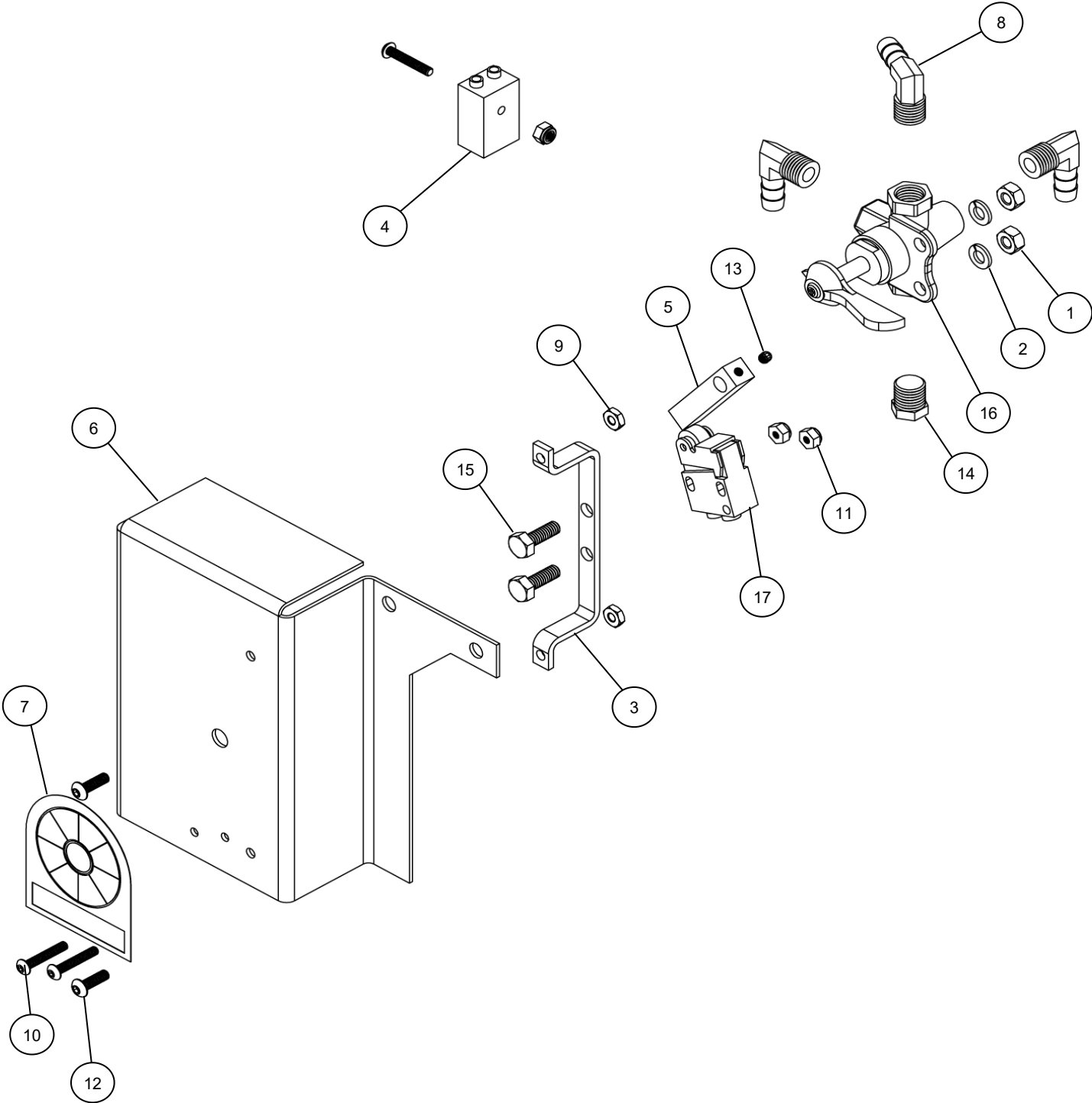

G202 Valve Layout

Part #	Description	Quantity
1 84	Hex Nut 1/4-20	2 EA.
2 85	Lock Washer 1/4	2 EA.
3 11217	Mounting Bracket	1 EA.
4 1000851	OR Valve	1 EA.
5 1000907	Valve Actuator	1 EA.
6 1002692	Valve Bracket	1 EA.
7 1002761	Manual Brush Sticker	1 EA.
8 1000967	Hose Barb 90° 3/8 x 1/4 NPT Brass	3 EA.
9 002-160	Hex Nut 10-32	2 EA.
10 002-171	Screw 8-32 x 1	3 EA.
11 002-172	Nylock Nut 8-32	3 EA.
12 002-173	Screw 10-32 x 5/8	2 EA.
13 004-723	Set Screw	1 EA.
14 59B	Hex Plug 1/4 NPT	1 EA.
15 83K	Hex Bolt 1/4-20 x 3/4	2 EA.
16 C26	Brush Valve	1 EA.
17 M1C	Limit Valve	1 EA.

Note: Parts are shown for reference purposes only and are not necessarily part of a Herkules assembly.

PART #:

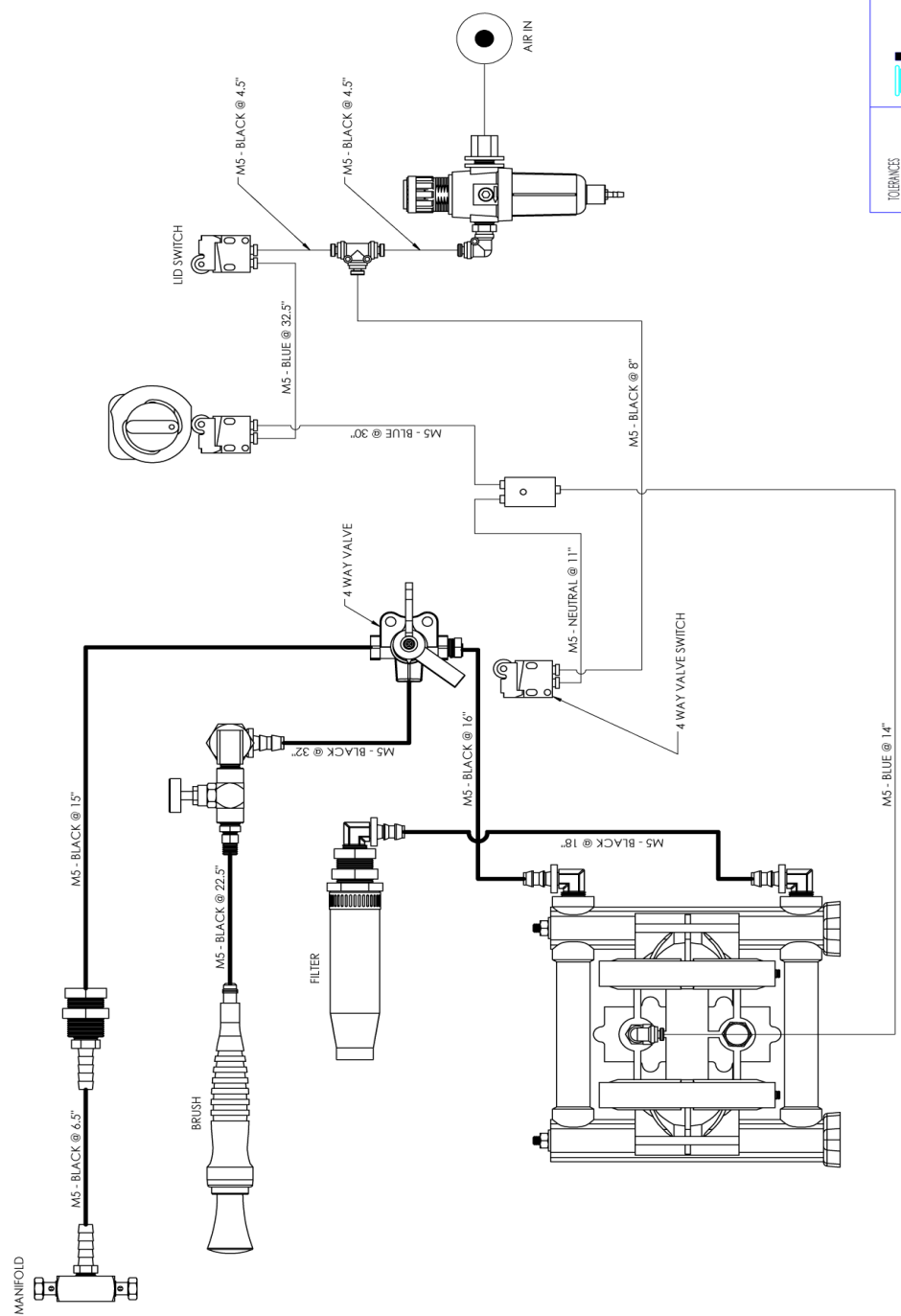

herkules™
 206 RIDGEWAY COURT • WALKED A/C M-6809-162
 FILE: G205 SCHEMATIC

TOLERANCES UNLESS OTHERWISE NOTED
 X + .250
 XX + .125
 XXX + 0.030
 XXXX + 0.0050
 ANGLE ± 1°

DWG: TCB 4/16/2019 MATERIAL:
 REF: CHD/C: DNG/C: REF: SHEET: 1 OF 1

CONFIDENTIAL
 THE INFORMATION CONTAINED ON THIS DRAWING IS BOTH CONFIDENTIAL AND PROPRIETARY. IT IS THE SOLE PROPERTY OF HERKULES EQUIPMENT CORPORATION. ANY REPRODUCTION IN PART OR AS A WHOLE WITHOUT THE WRITTEN PERMISSION OF HERKULES EQUIPMENT CORPORATION IS PROHIBITED AND MAY BE UNLAWFUL.

— AIR LINE
 — FLUID LINE