

AJ2 & AJ3

OWNER'S MANUAL



INSTRUCTIONS

This manual contains important information concerning the installation and operation of the products listed above. Read manual thoroughly and keep for future reference

PNEUMATIC AIR JACK

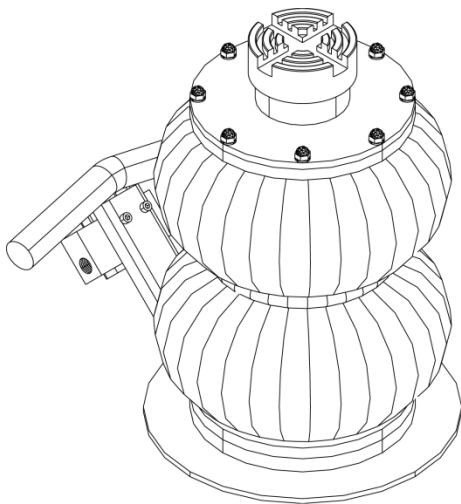

09981017(254)

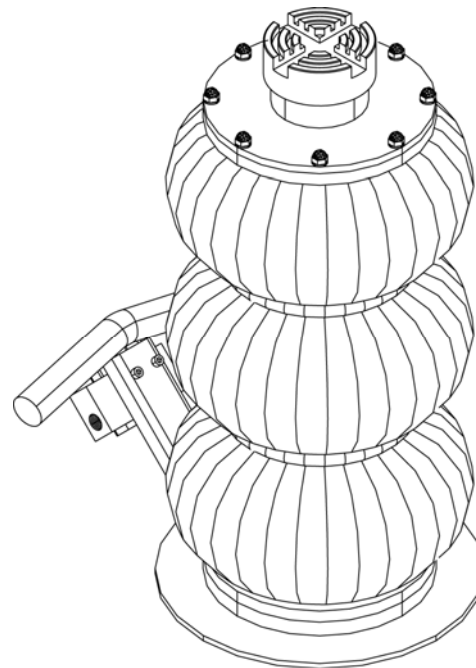

09981018(254)

Herkules Equipment Corporation ■ 2760 Ridgeway Court ■ Walled Lake, MI 48390-1662 USA
248-960-7100 ■ 1-800-444-4351 ■ Fax 248-960-7109
Website: www.herkules.us Made in the USA email: info@herkules.us

Model Information:

Model	Capacity (kg)	Pressure (bar)	Maximum Lift (mm)	Weight (kg)
AJ2	4500 lbs (2041)	100 psi (7)	13.56 in (345)	28 lbs (12.7)
AJ3	4500 lbs (2041)	100 psi (7)	19.25 in (490)	37 lbs (16.78)

Installation:

Connecting the Air Line

1. Install a 1/4 in. NPT male couple, that is compatible with the quick disconnect of your air supply line, into the air inlet of the air jack. See Figure 1.
2. Connect air line with at least 100 psi (7 bar) pressure to the quick disconnect coupler.

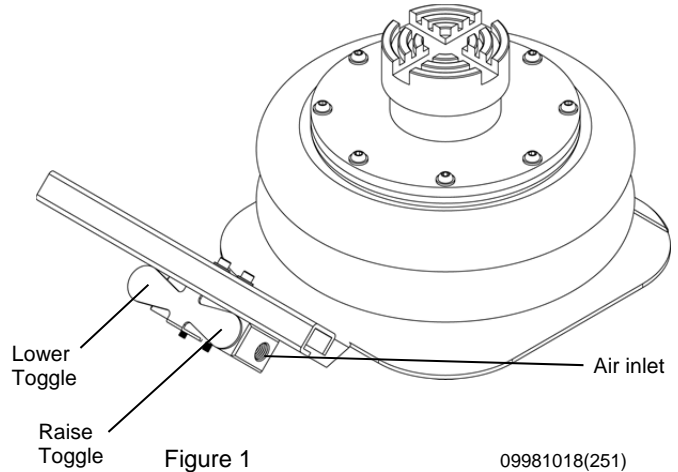

Operation:

1. Position the air jack under the vehicle to be lifted and press the Raise Toggle (green arrow) on the air valve.
Note: Lift only at vehicle manufacturer's specified lift points.
2. Once the repair operations on the vehicle have been completed, press the Lower Toggle (red arrow) on the air valve to lower the vehicle. See Figure 1 & 2.



Lower Toggle
(Red Arrow)

Raise Toggle
(Green Arrow)

Figure 2

CAUTION: It is critical that the air jack and the vehicle are on level planes. Furthermore the surface on which the air jack is to be used has to be free from loose debris and level. See Figure 3.

CAUTION: The AJ-2 and AJ-3 Air Jacks are *not* lifts. For this reason never work under the vehicle when using an air jack.

CAUTION: Do not leave vehicle in raised Position over night.

NOTE: The air jack is equipped with a pressure relief valve to prevent over inflation.

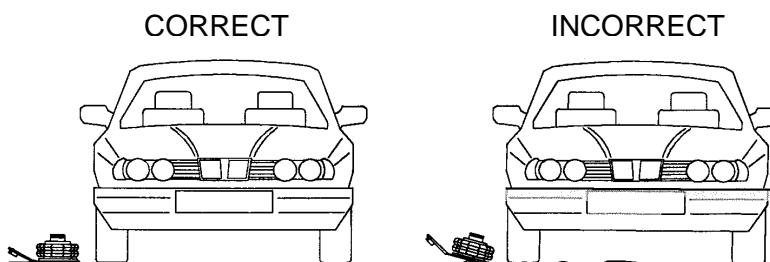

Figure 3



1. It is critical that the air jack and vehicle are on level planes (see fig.3).
2. The surface under the air jack must be free of debris and level.
3. The AJ2 & AJ3 Air Jacks are NOT a stand. Never work under the vehicle supported by only the Air Jack.
4. DO NOT leave vehicle in raised position over night.
5. The air jack is equipped with a pressure relief valve to prevent over inflation. DO NOT continue to fill the air bag once raised height is achieved even though pressure relief valve will prevent over-inflation. Maximum air pressure is 100-110 p.s.i.
6. Do not exceed rated capacity (4,500 lbs)
7. Lift only on areas of the vehicle as specified by the vehicle manufacturer.
8. Avoid contact with petroleum based products or chemicals of any kind.
9. Avoid sharp objects near bag. Bag penetration will result in jack dropping without warning, which will result in serious injury or property damage.
10. Only attachments and/or adapters supplied by the manufacturer shall be used.
11. Keep hands away from jack base pad at all times.
12. Make sure jack is secure at lift point.
13. With air line disconnected, the air bag can be deflated by pressing either arrow on the handle.

Maintenance

1. On a monthly basis, add a few drops of pneumatic tool oil to air inlet.
2. Visually inspect the Air Jack before each use. Do not use the Air Jack if you detect scars, abrasions, rips, or punctures in the air bag. If so, the Air Jack should be returned to Herkules for inspection and evaluation.

AIR JACK PARTS LAYOUT

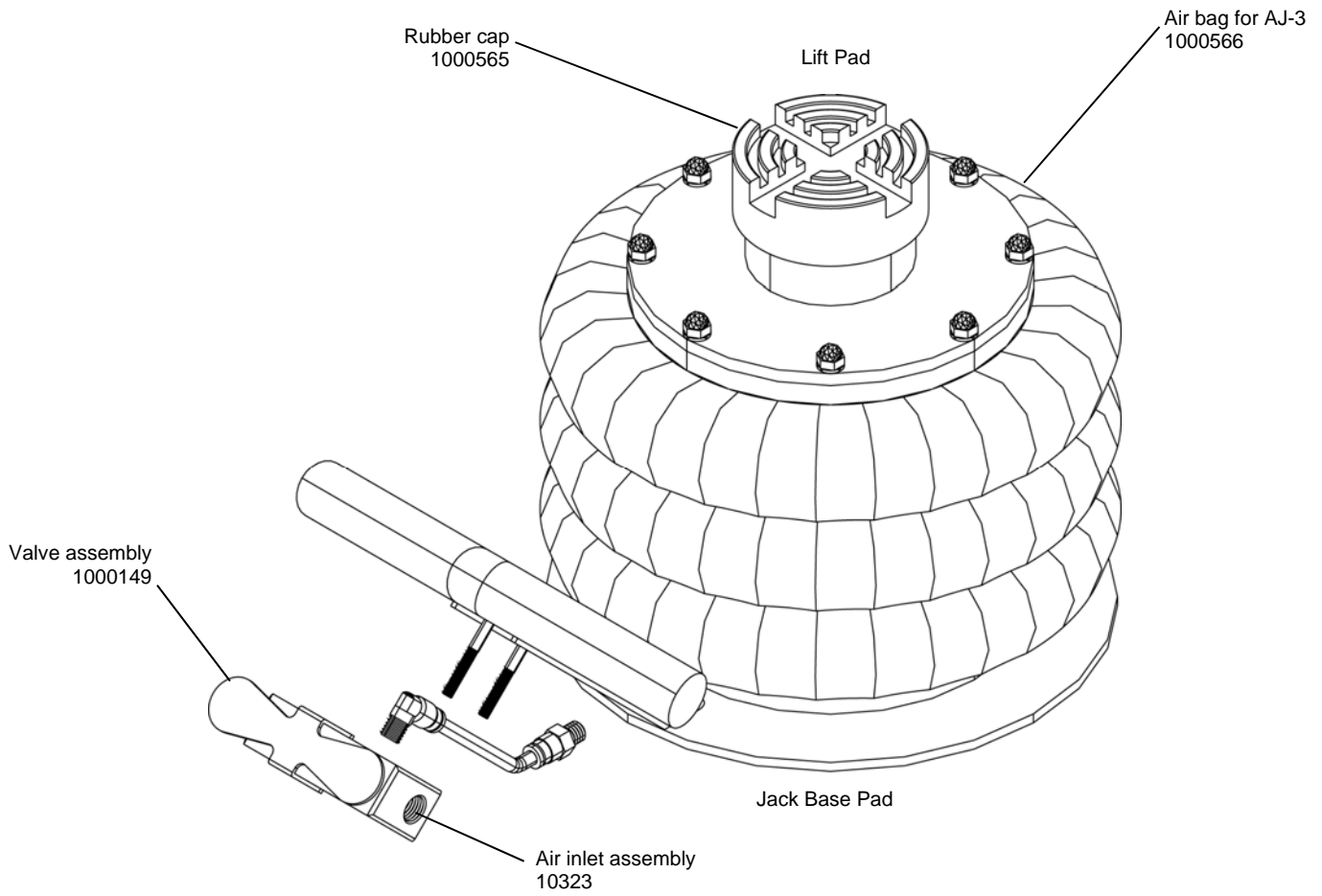

Optional Equipment

Height Extender 2.0 inches	AJ-X50
Height Extender 4.0 inches	AJ-X100
Pinch Weld Adapter	10454