

L1200P

OWNERS MANUAL



INSTRUCTIONS

This manual contains important information concerning the installation and operation of the automobile lift listed above. Read manual thoroughly and keep for future reference

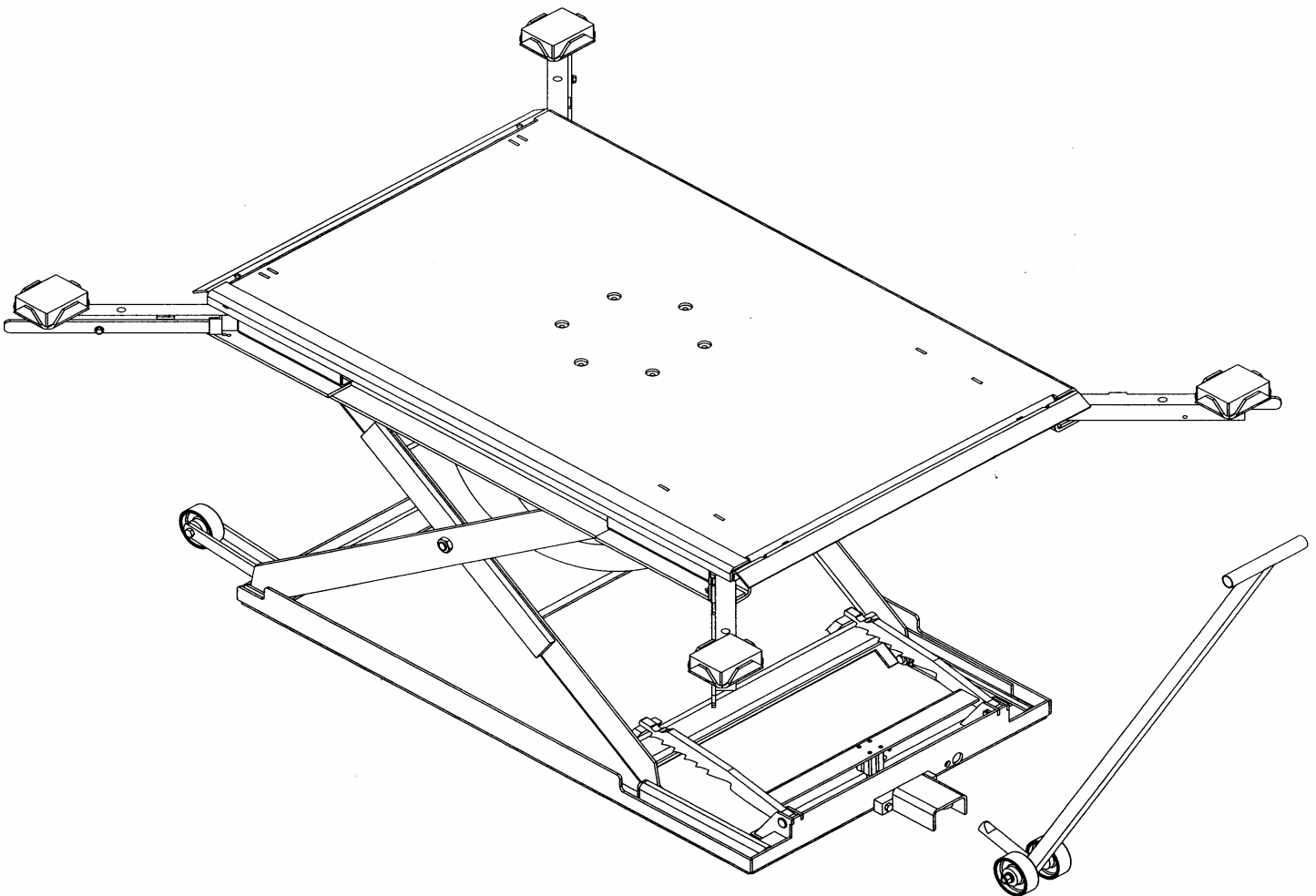

Herkules Equipment Corporation
248-960-7100

2760 Ridgeway Court
800-444-4351

Walled Lake, MI 48390-1662 USA
Fax 248 960-7109

Patents USA 7070167 4793369, 4960142, 5174317, 5193561, 5485860 Canada 1299468 & Patents Pending

website: www.herkules.us

Made in the USA

e-mail: info@herkules.us

Table of Contents

Warnings	3
Model Information	4
Installation	5
Operation	7
Maintenance Instructions	9
Troubleshooting	9
Optional Accessories	10
Parts List	11
Controller Layout	12

Warning Symbol



This symbol alerts you to the possibility of serious injury or death if you do not follow the instructions.

Caution Symbol



This symbol alerts you to the possibility of damage to or destruction of equipment if you do not follow the instructions.

Serial Number _____

Model Number _____

Purchase Date _____

Distributor _____

This product has patent protection under one or more of the following patent numbers:

7070167, 5485860, 5193561, 5174317
4960142, 4793369, 1299468
and Patents Pending

website: www.herkules.us 1002742

Limited Liability Warranty

The limited liability warranty applies to the pneumatic chambers of our Herkules lifts and to the initial user against defective materials for a period of five years from the proof of purchase date. The limited liability warranty applies to other components of our Herkules lifts to the initial user against defective materials for a period of one year from the proof of purchase date.

This warranty does not apply to equipment damaged from accident, abuse, overload, misuse, negligence, improper installation, abrasive or corrosive materials, or shipping damage.

In the event of failure, the defective item must be returned, freight prepaid, to the Herkules manufacturing plant for repair or replacement. If repairs are required Herkules will not be liable for these repairs to take place in the field regardless of the application. Proof of purchase and date of purchase must be confirmed. An RGA number (Return Goods Authorization) and written approval from Herkules must be obtained before any goods can be shipped to Herkules. Herkules reserves the right to determine whether the cause of failure is due to defective material, normal wear, and/or other causes.

Warnings

THIS MANUAL CONTAINS IMPORTANT INFORMATION CONCERNING THE INSTALLATION AND OPERATION OF VEHICLE LIFTS.

WE OFFER TWO SUGGESTIONS:

- READ ALL MANUALS THOROUGHLY BEFORE INSTALLATION.
- KEEP ALL MANUALS FOR FUTURE REFERENCE.

CAUTION

- 1 Do not exceed the rated load capacity of the lift.
- 2 Do not continue to push the control lever after lift is fully raised, even though safety valve will prevent over-inflation of air bag.
- 3 Use lift only on level surfaces.
- 4 Keep clear of lift while it is in motion.
- 5 Do not use air supply exceeding 120 PSI.
- 6 Do not leave a vehicle raised on the lift overnight.
- 7 Do not operate lift with defective Control assembly.
- 8 Never for any reason put arm or any other body part inside lift.

WARNING

- 1 Herkules will not be held responsible for any personal injury and/or property damage due to owner/operator failure to follow the warnings and cautions listed in this manual.
- 2 Read and understand all warnings, cautions, instructions and manuals before operating this equipment.
- 3 It is the owner/operators responsibility to maintain the legibility of all warning and instruction labels.
- 4 DO NOT alter or modify any part of this equipment.
- 5 DO NOT attempt to bypass the safety lock system.
- 6 DO NOT tamper with pressure relief valve system inside the lift.
- 7 DO NOT operate lift while person(s) are in the vehicle
- 8 ALWAYS check equipment regularly for proper operation and repair or replace worn or damaged parts immediately.
- 9 ALWAYS remove damaged lifts from service until repairs are made to the unit. Use only manufacturer's approved parts and accessories.

REV	DESCRIPTION	DATE	APPROVED

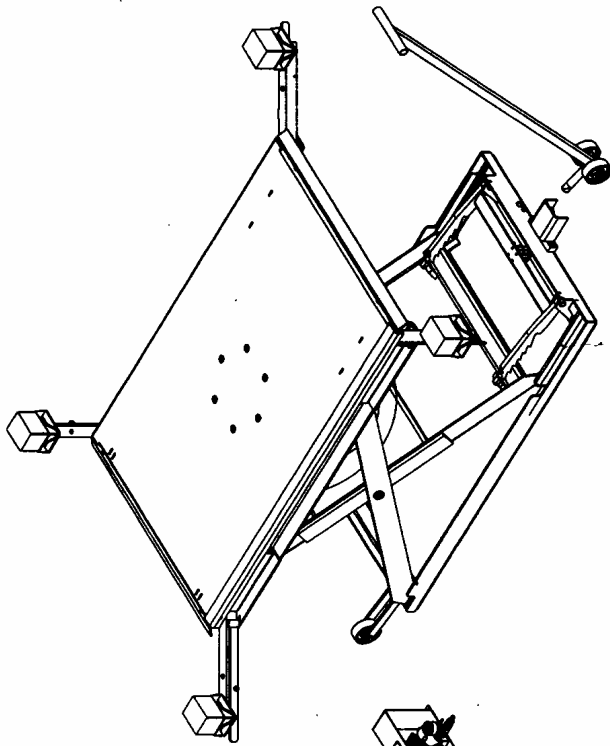

FOOT CONTROL
UP - SPRING RETURN
DOWN - SPRING RETURN

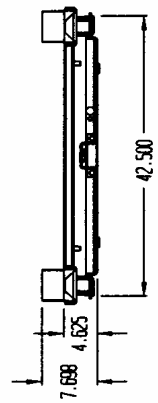
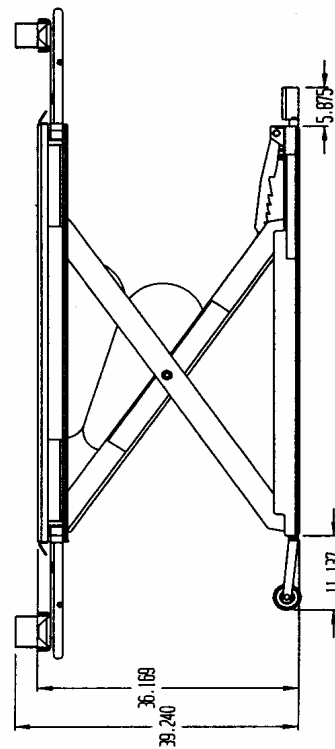
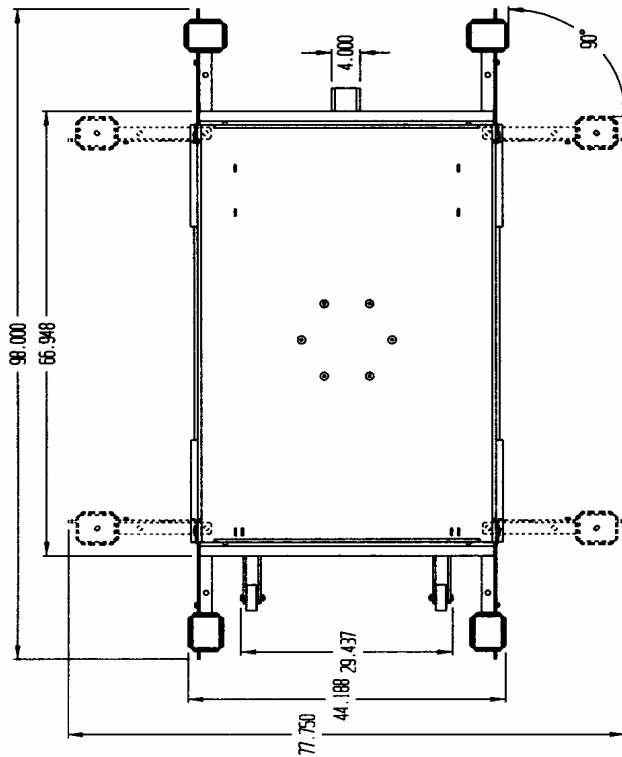

POS	PART #	MATERIAL	DESCRIPTION	QTY	UNIT
hercules™ 2700 ROSENTH COURT • WALL LANE, N.J. 07682 TITLE: LIFT VEHICLE ADJ SWG ARMS PORTABLE DRAWING NO.: 02033559 DATE: P. 6-29-05 PART #: L1200P					

PART # L1200P

Installation

STEP 1

Locate lift on a level surface in a position most convenient for the loading and unloading of vehicles.

STEP 2

Obtain hose clamps:

ID	Part #	Description	Qty.
1	720-122	CLAMP HOSE # 4 SS/Z	1
2	1001942	CLAMP HOSE CRIMP TYPE 1" Z	1

STEP 3

Using the 1" hose clamp (1001942), clamp the 5/8" ID air line (1001274) from the lift to 5/8" hose barb (1001393) on the foot control assembly (see fig.2).

STEP 4

Using the #4 hose clamp (720-122), clamp the 1/4" ID air line (720-106) from the lift to hose barb (990) on the foot control assembly (see fig.2).

NOTE: Check these connections periodically to prevent leakage.

STEP 5

Obtain 1/2 NPT connector compatible with the quick disconnect on your shop air line.

NOTE: Connector not supplied with lift.

STEP 6

Install 1/2 NPT connector into open port (Port 1) on the foot control valve (see fig.1).

STEP 7

Connect your shop air line to connector and test for proper operation.

NOTE: Must use clean, dry air only. Herkules recommends using a filter/regulator (see Optional Accessories).

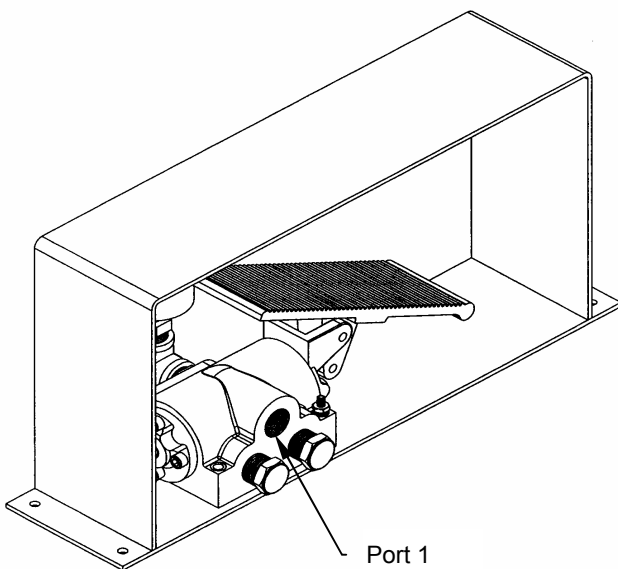
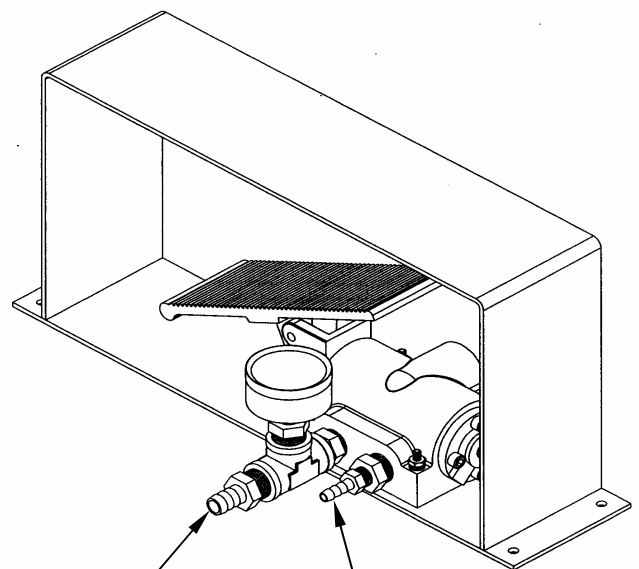

fig.1



5/8" Hose barb
1001393

fig.2

1/4" Hose barb
990

Installation

STEP 8

Obtain wheels, mounts, and hardware (see fig.3):

ID	Part #	Description	Qty.
1	500-122B	Hex Bolt 1/2-13 x 3	2
2	84J	Lock Nut 1/2-13	2
3	10504	Wheel Mount Assembly	2
4	693-110	Wheel	2

STEP 9

Install each wheel (693-110) to the mounts (10504) using (1) Hex Bolt 1/2-13 x 3 (500-122B) and (1) Lock Nut 1/2-13 (84J) per assembly (see fig.3).

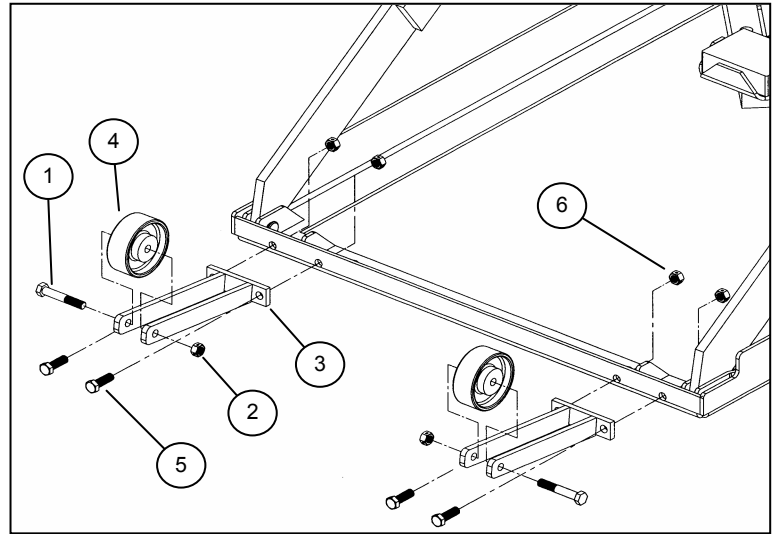

fig.3

STEP 10

Obtain mounting hardware (see fig.3):

ID	Part #	Description	Qty.
-	-	Assembly from steps 8-9	2
5	83J	Hex Bolt 1/2-13 x 1-1/2	4
6	84J	Lock Nut 1/2-13	4

STEP 11

Install each wheel assembly to the bottom lift pan using (2) Hex Bolt 1/2-13 x 1-1/2 (83J) and (2) Lock Nut 1/2-13 (84J) per assembly (see fig.3).

NOTE: Install the wheel assemblies so that the lift continues to sit flat and the wheel arms are angled upwards away from the floor.

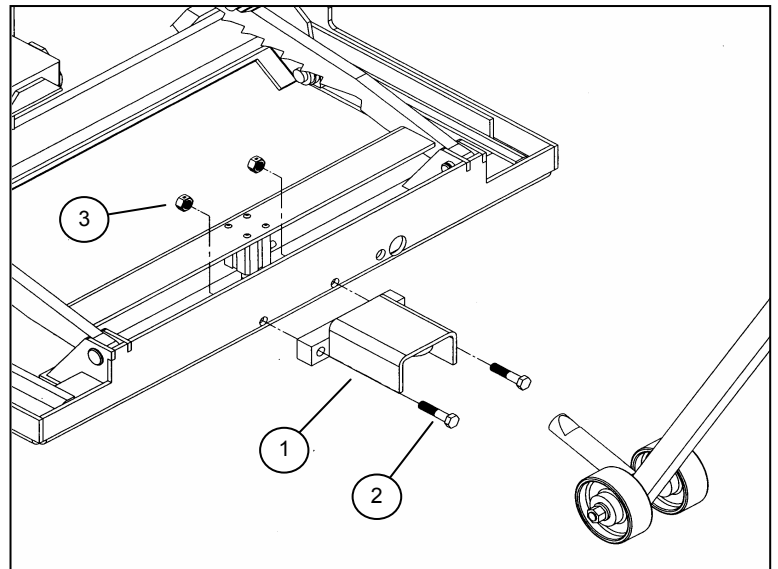

fig.4

STEP 12

Obtain hitch assembly and hardware (see fig.4):

ID	Part #	Description	Qty.
1	10502	Hitch Assembly	1
2	1002270	Hex Bolt 7/16-14 x 2	2
3	1002271	Nut Nylock 7/16-14	2

STEP 13

Install the hitch assembly (10502) to the bottom lift pan using (2) Hex Bolt 7/16-14 x 2 (1002270) and (2) Nut Nylock 7/16-14 (1002271) (see fig.4).

Operation

STEP 1

Check the weight of the vehicle to be sure that it does not exceed the rated load capacity of the lift: **6,000 lbs.**

STEP 2

Move the Lift Pad Arms into the maximum clearance position (see fig.5).

STEP 3

Position the vehicle over the lift so that it is approximately centered by weight over the center of the lift. Once the vehicle is in the desired position, set parking brake.

STEP 4

Move the Lift Pad Arms into position under the vehicle manufacturer's recommended lifting points. Position desired rubber block on each arm to best accommodate the clearance to each lifting point.

STEP 5

To raise the lift, press the pedal of the foot controller assembly toward the UP position. Hold the pedal in the UP position until vehicle has reached the desired working height, then release. The mechanical safety arms will automatically fall into position as the lift rises.

Do not continue to push the control lever after lift is fully raised, even though safety valve will prevent over-inflation of air bag.

NOTE: Check the stability of the vehicle during the lifting process, and when vehicle is at desired working height. If vehicle is unstable, immediately stop the lifting process, slowly lower the lift and reposition Lift Pad Arms.

STEP 6

To lower the lift, press the pedal of the foot controller assembly towards the DOWN position. Hold the pedal in the DOWN position until the lift is completely lowered and the vehicle's wheels are on the ground. The mechanical safety arms will swing up during descent.

It may be necessary to raise the lift slightly before lowering to relieve pressure on safety arms.

NOTE: Check the stability of the vehicle during the lowering process. If vehicle is unstable, immediately stop and diagnose the issue before continuing to lower the lift.

STEP 7

Once the lift is completely lowered, remove the rubber blocks and return the Lift Pad Arms to the maximum clearance position (see fig.5). Drive the vehicle clear of the lift.

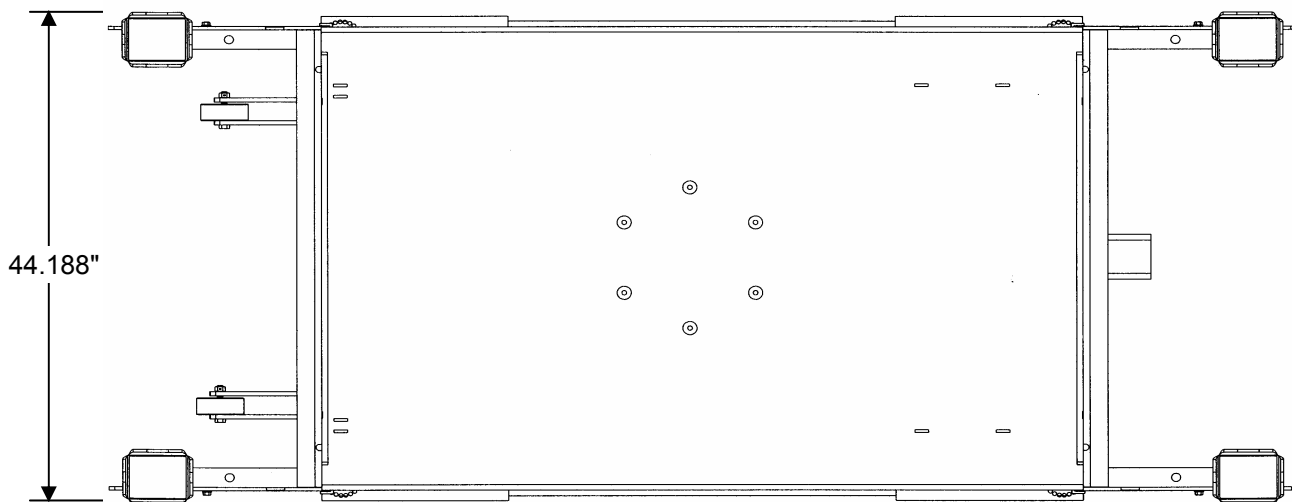

fig.5

Portability Operation

- ▶ *DO NOT attempt to move the lift while loaded with a vehicle or any other object.*
- ▶ *DO NOT attempt to move the lift while in the raised position.*
- ▶ *Ensure air line is disconnected and lift is not anchored to the floor (if applicable).*

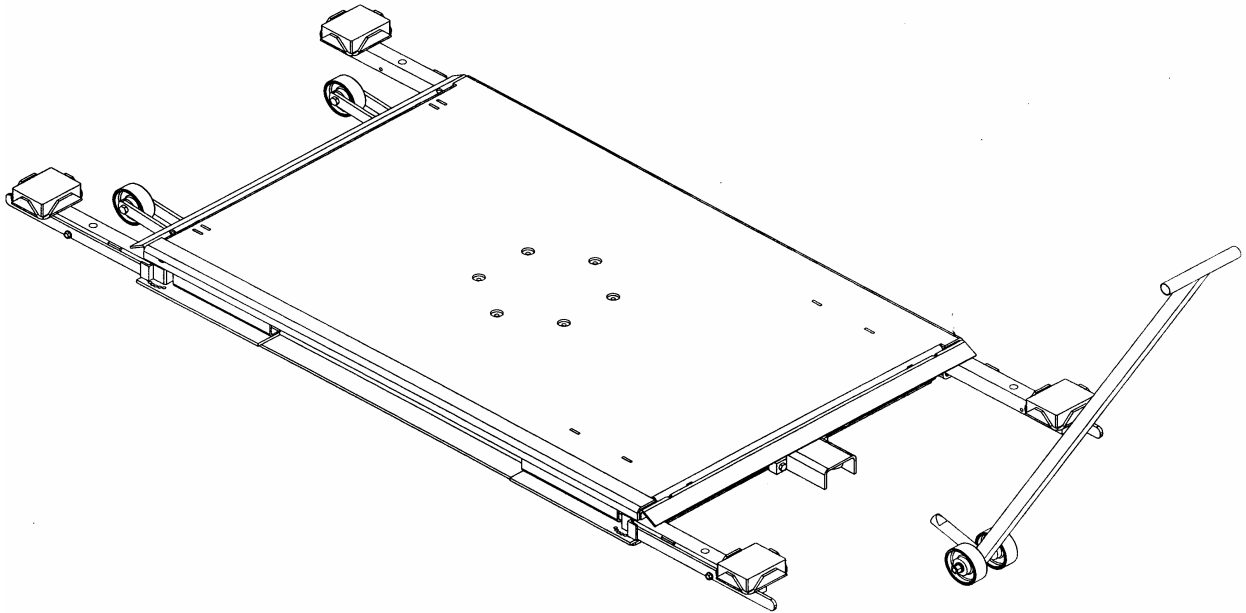

fig.6

STEP 1

Hook the roller end of the portability handle into the portability hitch on the lift and pull down on the handle to tilt the lift on to the wheels at the opposite end of the lift.

STEP 2

Move the lift to the desired location, raise the handle and ensure the lift is sitting flat in the new location.

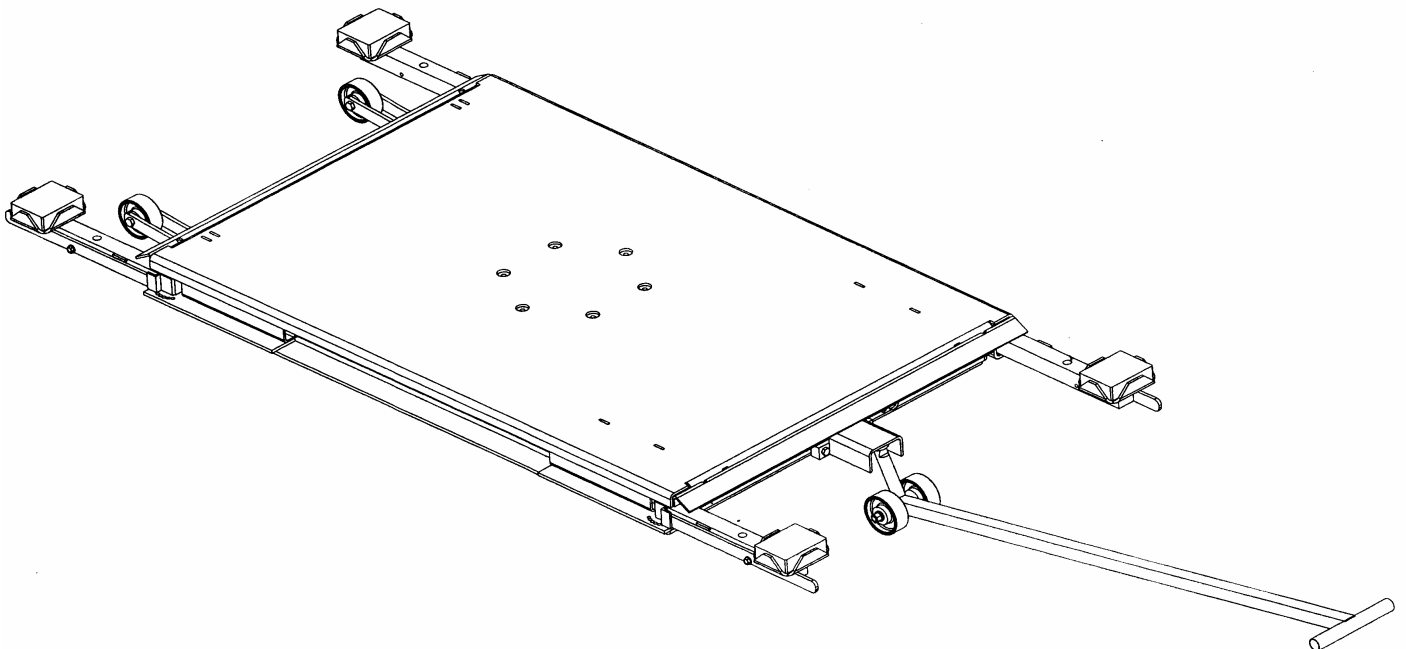

fig.7

Maintenance Instructions

STEP 1

Check clamps and hose connections periodically for tightness to prevent air leakage.

STEP 2

Make sure all moving parts are clean and unobstructed by foreign objects.

STEP 3

Clean filter element every 3 months if applicable.

STEP 4

Grease and oil pivot points once every 3 months.
Lubricate daily if lift is in high cycle application.

STEP 5

Use 90-weight gear lube (SAE 85W 140 EP) to lubricate the pivots and shafts once every 3 months or as needed.

STEP 6

Grease the upper and lower wheel channels every 3 months or as needed.

STEP 7

Lubricate lock mechanism pivot points every 3 months or as needed.

STEP 8

Use overhead rigging when any maintenance beyond external lubrication is required.

Troubleshooting

Problem	Possible Solution
Lift will not go up	<ol style="list-style-type: none"> 1 Check that air inlet is connected to the controller. 2 Check to ensure lockout is not engaged (if purchased as option). 3 Check air hoses to ensure no kinks or cuts in the line. 4 Check to ensure no debris is preventing wheels from rolling in track. 5 Check regulator gauge is set to minimum of 80 psi (if purchased as option).
Lift is making a hissing noise	<ol style="list-style-type: none"> 1 Check all air lines to ensure they are properly connected and no leaks are occurring. 2 Check pressure relief valve. <i>If pressure relief valve is "leaking" lower lift immediately. The air bag is in a state of over pressurization.</i> 3 Check air bag for cuts or holes.
Lift is making a squeaking noise	<ol style="list-style-type: none"> 1 Lubricate center joints and wheel tracks.

Optional L1200 Accessories

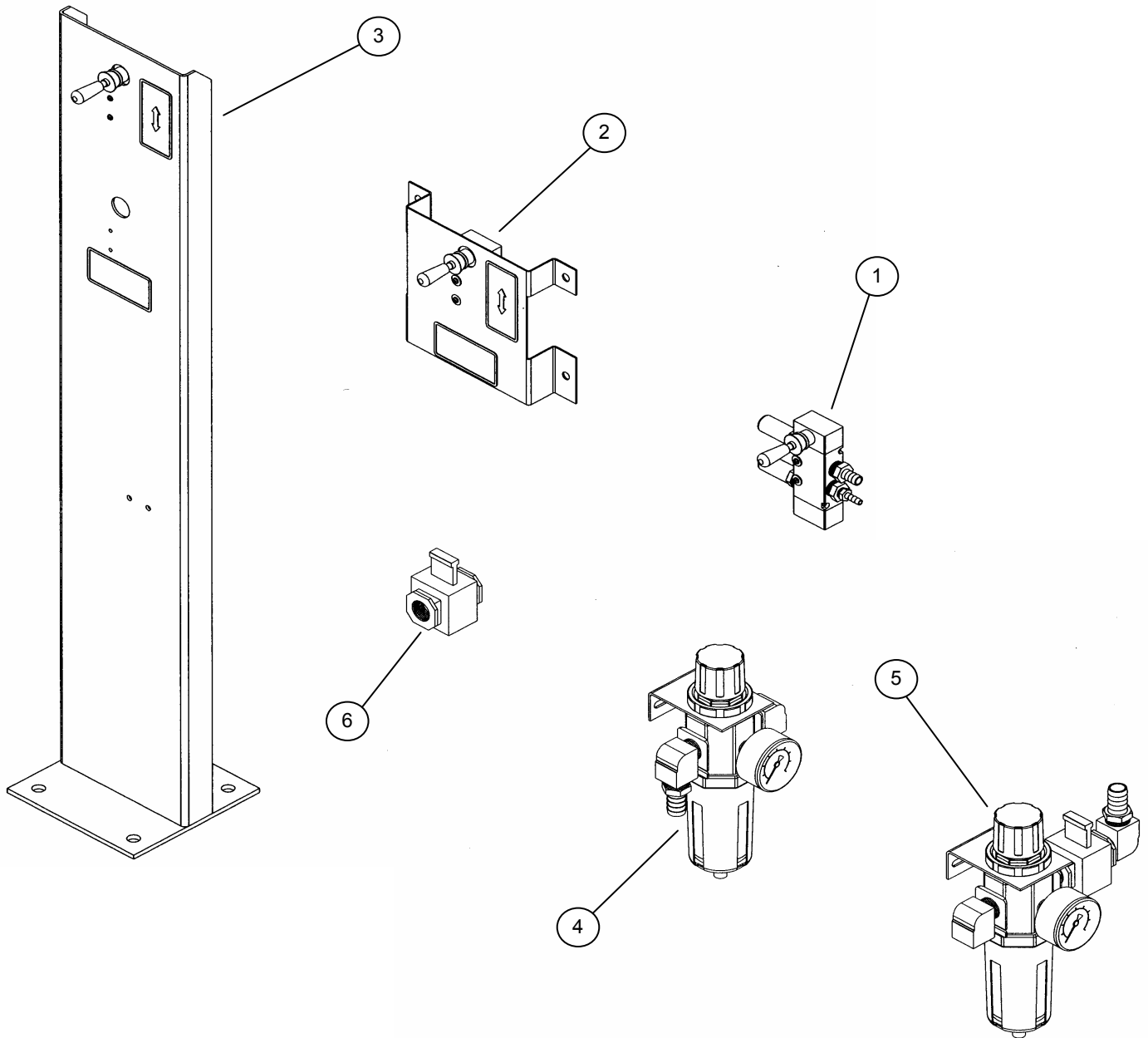

ID	Part #	Description	Qty	Units
1	12853	Control Valve Assembly - Hand - Lift Only - 2 x Muffler	1	EA
2	12854	Control Assembly - Hand - Lift Only - Wall Mount	1	EA
3	12858	Control Assembly - Hand - Lift Only - Pedestal Mount	1	EA
4	12880	Filter / Regulator Assembly	1	EA
5	12881	Filter / Regulator / Lock Out Assembly	1	EA
6	1002450	Lock Out Valve	1	EA
-	12368	Set of (4) Rubber Blocks - 3-7/8 x 5 x 1-1/2	1	EA
-	12371	Set of (4) Rubber Blocks - 4-3/4 x 4 x 3-1/8	1	EA

Parts List

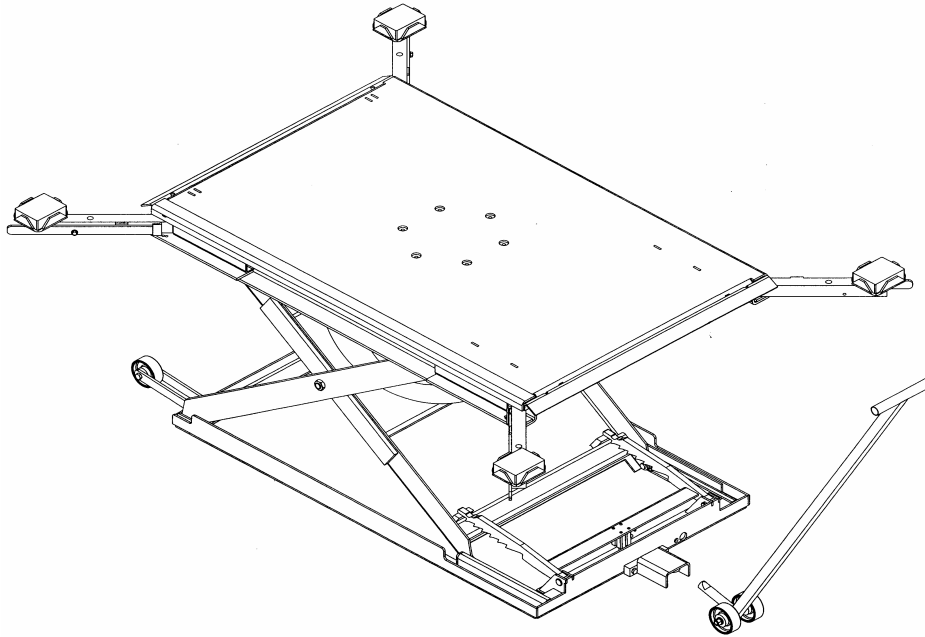

Part #	Description	Quantity	Units
994	BLOCK 3-7/8 X 5 X 1-1/2	4	EA.
11177	BOTTOM PAN WLDMT FOR L-1200	1	EA.
11178	INNER SCISSOR WLDMT FOR L-1200	1	EA.
11179	TOP PAN WLDMT FOR L-1200	1	EA.
11182	OUTER SCISSOR L WLDMT FOR L-1200	1	EA.
11183	OUTER SCISSOR R WLDMT FOR L-1200	1	EA.
11185	SAFETY RATCHET WLDMT FOR L-1200	1	EA.
11296	BLOCK KEEPER FOR L-1200 PLATED	4	EA.
11297	SWING ARM ASSY-A FOR L-1200	2	EA.
11298	SWING ARM ASSY-B FOR L-1200	2	EA.
11327	AIR CYLINDER ASSEMBLY FOR L-1200	1	EA.
11328	FOOT CONTROLLER ASSEMBLY FOR L-1200	1	EA.
11585	BOLT HEX 7/8-14 CUT AT 2-3/4	2	EA.
1001205	AIR BAG FOR L-SERIES LIFTS	1	EA.
1001274	HOSE 5/8 ID 250 PSI RUBBER	240	IN.
1001355	BLOCK FOR L-1200 SCISSOR NYLON	6	EA.
1001844	HOSE 1/4 ID 250 PSI RUBBER	216	IN.
1001910	HOSE PROTECTION SLEEVE 1/2"	4	IN.
1001911	HOSE PROTECTION SLEEVE 3/4"	12	IN.
1001925	BOLT SHC 8MM-20 X 20MM Z	12	EA.
1001926	BOLT HEX 5/16-18 X 5/8 GD 8 Z	6	EA.
1001927	WASHER BONDED 5/8 ODX5/16 ID SS/NEO	12	EA.
1001928	VALVE PRES RELIEF 3/8 NPT X 55 PSI	1	EA.
1001929	HOSE BARB 5/8 X 3/8 NPT	1	EA.
1001934	NUT JAM LOCK 7/8-14 Z	2	EA.
1001936	PIN 18MM X 45MM HARDENED FOR L-1200	4	EA.
1001937	PIN 18MM X 55MM HARDENED FOR L-1200	2	EA.
800-105	BLOCKS 120 X 100 X 80 MM	4	EA.
83J	BOLT HEX 1/2-13 X 1-1/2 Z	4	EA.
84J	NUT LOCK 1/2-13 Z	4	EA.
84L	NUT NYLOCK 5/16-18 Z	6	EA.
85D	WASHER FLAT 1/2 SAE MIN TH .110 Z	8	EA.
10501	PORTABLILITY KIT FOR L-SERIES LIFTS	1	EA.

see pg.12

Controller Layout

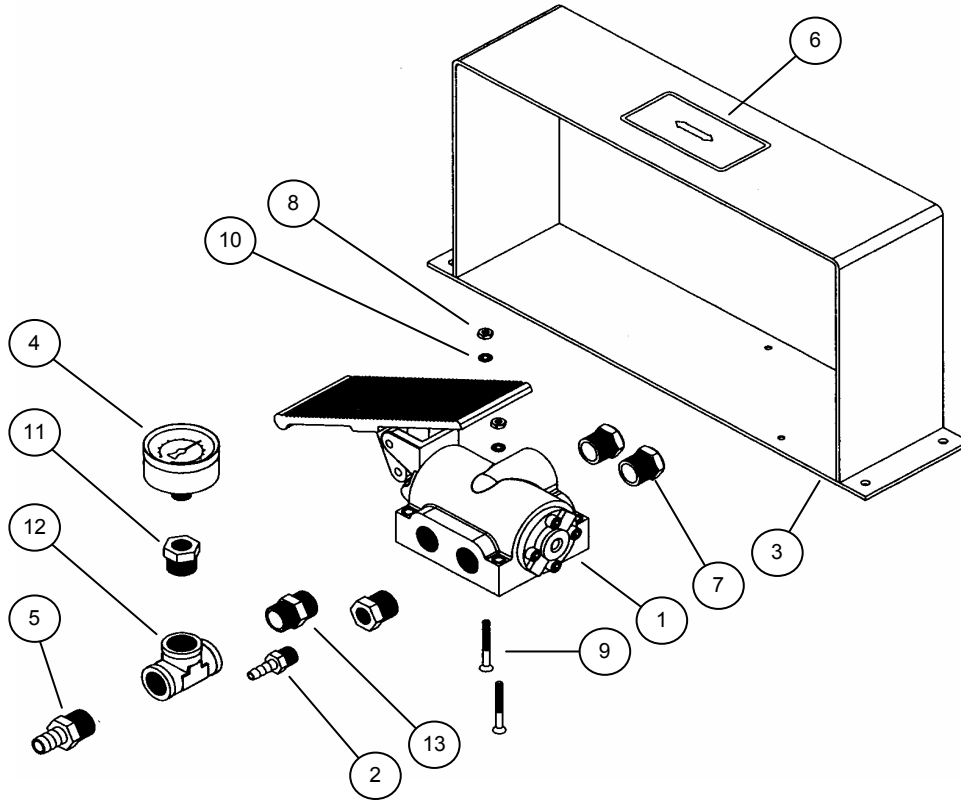

ID	Part #	Description	Qty	Units
1	754	VALVE 4-WAY FOOT CONTROL 1/2 NPT	1	EA.
2	990	HOSE BARB 1/4 X 1/4 NPT BRASS	1	EA.
3	10071	CNTRL MOUNT WELDM SINGLE FOOT	1	EA.
4	1000205	AIR GAUGE 0-160 1/4 NPT BP	1	EA.
5	1001393	HOSE BARB 5/8 X 1/2 NPT BRASS	1	EA.
6	1001592	STICKER LIFT UP-DOWN-INDUSTRIAL	1	EA.
7	1001602	VENT BREATHER 1/2 FOR LIFT CONTROLS	2	EA.
8	002-160	NUT HEX 10-32 Z	2	EA.
9	009-148	SCREW FHSC 10-32 X 1-3/4 BLACK	2	EA.
10	24E	WASHER LOCK INT TOOTH #10 Z	2	EA.
11	66B	RED. BUSHING 1/2 NPT X 1/4NPT BRASS	2	EA.
12	C12G	TEE 1/2 NPT BRASS	1	EA.
13	M25D	NIPPLE HEX 1/2 NPT BRASS	1	EA.

NOTE: Entire controller assembly is part number 11328